

ASME B16.9-2018
(Revision of ASME B16.9-2012)

Factory-Made Wrought Buttwelding Fittings

AN AMERICAN NATIONAL STANDARD



**The American Society of
Mechanical Engineers**

ASME B16.9-2018
(Revision of ASME B16.9-2012)

Factory-Made Wrought Buttwelding Fittings

AN AMERICAN NATIONAL STANDARD



**The American Society of
Mechanical Engineers**

Two Park Avenue • New York, NY • 10016 USA

Date of Issuance: October 29, 2018

The next edition of this Standard is scheduled for publication in 2023.

ASME issues written replies to inquiries concerning interpretations of technical aspects of this Standard. Periodically certain actions of the ASME B16 Committee may be published as Cases. Cases and interpretations are published on the ASME website under the Committee Pages at <http://cstools.asme.org/> as they are issued.

Errata to codes and standards may be posted on the ASME website under the Committee Pages to provide corrections to incorrectly published items, or to correct typographical or grammatical errors in codes and standards. Such errata shall be used on the date posted.

The Committee Pages can be found at <http://cstools.asme.org/>. There is an option available to automatically receive an e-mail notification when errata are posted to a particular code or standard. This option can be found on the appropriate Committee Page after selecting "Errata" in the "Publication Information" section.

ASME is the registered trademark of The American Society of Mechanical Engineers.

This code or standard was developed under procedures accredited as meeting the criteria for American National Standards. The Standards Committee that approved the code or standard was balanced to assure that individuals from competent and concerned interests have had an opportunity to participate. The proposed code or standard was made available for public review and comment that provides an opportunity for additional public input from industry, academia, regulatory agencies, and the public-at-large.

ASME does not "approve," "rate," or "endorse" any item, construction, proprietary device, or activity.

ASME does not take any position with respect to the validity of any patent rights asserted in connection with any items mentioned in this document, and does not undertake to insure anyone utilizing a standard against liability for infringement of any applicable letters patent, nor assume any such liability. Users of a code or standard are expressly advised that determination of the validity of any such patent rights, and the risk of infringement of such rights, is entirely their own responsibility.

Participation by federal agency representative(s) or person(s) affiliated with industry is not to be interpreted as government or industry endorsement of this code or standard.

ASME accepts responsibility for only those interpretations of this document issued in accordance with the established ASME procedures and policies, which precludes the issuance of interpretations by individuals.

No part of this document may be reproduced in any form,
in an electronic retrieval system or otherwise,
without the prior written permission of the publisher.

The American Society of Mechanical Engineers
Two Park Avenue, New York, NY 10016-5990

Copyright © 2018 by
THE AMERICAN SOCIETY OF MECHANICAL ENGINEERS
All rights reserved
Printed in U.S.A.

CONTENTS

Foreword	v
Committee Roster	vi
Correspondence With the B16 Committee	vii
Summary of Changes	ix
List of Changes in Record Number Order	x
1 Scope	1
2 Pressure Ratings	1
3 Size	2
4 Marking	2
5 Material	3
6 Fitting Dimensions	3
7 Surface Contours	3
8 End Preparation	3
9 Design Proof Test	3
10 Production Tests	5
11 Tolerances	5
 Mandatory Appendix	
I References	28
 Nonmandatory Appendix	
A Quality System Program	29
 Figure	
8-1 Maximum Envelope for Welding End Transitions	24
 Tables	
5-1 Material Groupings	6
6.1-1 Dimensions of Long Radius Elbows	7
6.1-2 Dimensions of Long Radius Reducing Elbows	8
6.1-3 Dimensions of Long Radius Returns	9
6.1-4 Dimensions of Short Radius Elbows	9
6.1-5 Dimensions of Short Radius 180-deg Returns	10
6.1-6 Dimensions of 3D Radius Elbows	11
6.1-7 Dimensions of Straight Tees and Crosses	12
6.1-8 Dimensions of Reducing Outlet Tees and Reducing Outlet Crosses	13
6.1-9 Dimensions of Lap Joint Stub Ends	19
6.1-10 Dimensions of Caps	20

6.1-11	Dimensions of Reducers	21
8-1	Welding Bevels and Root Face	23
9.2.1-1	Testing Coverage	25
9.3.1-1	Test Factor, f , Determination	25
11-1	Tolerances	26

FOREWORD

In 1921, the American Engineering Standards Committee, later the American Standards Association (ASA), organized Sectional Committee B16 to unify and further develop national standards for pipe flanges and fittings (and later, for valves, gaskets, and valve actuators). Cosponsors of the B16 Committee were The American Society of Mechanical Engineers (ASME), the Heating and Piping Contractors National Association [now the Mechanical Contractors Association of America (MCAA)], and the Manufacturers Standardization Society of the Valve and Fittings Industry (MSS). Cosponsors were later designated as cosecretariat organizations.

Standardization of welding fittings was initiated in 1937 by a subgroup (designated Subgroup 6) of Subcommittee 3. After consideration of several drafts, a standard was approved by the Committee, cosponsors, and ASA, and published with the designation ASA B16.9-1940.

Revisions were made in 1950 and 1955 to add sizes up to NPS 24 and to complete coverage of fittings in some sizes. These revisions were approved and published as ASA B16.9-1951 and ASA B16.9-1958. With the subgroup now designated Subcommittee 6 (later Subcommittee F), further revisions were begun to clarify the intent of the Standard, to add angularity tolerances, and to include fittings of different types (long radius reducing elbows and crosses) and smaller sizes (NPS $\frac{1}{4}$ and NPS $\frac{1}{2}$). This revision was published as ASA B16.9-1964 after ASA approval.

After reorganization of ASA, first as the United States of America Standards Institute (USASI), then as the American National Standards Institute (ANSI), with the Sectional Committee being redesignated as an American National Standards Committee, another revision increasing the size range to NPS 48 and revising the text for clarity was approved and published as ANSI B16.9-1971.

In 1975, Subcommittee F began a major revision to bring the standard up to date with current practice and usage. Common fractions were expressed as decimals (but without intending higher precision) and metric dimensional equivalents were added. Provisions for step-wise change of radius for NPS $\frac{3}{4}$ long radius elbows and 180-deg returns were introduced. Following Standards Committee, cosecretariat, and ANSI approval, the revision was published as ANSI B16.9-1978. It was updated by a corrective addendum, B16.9a-1981, issued in February 1982.

In 1982, American National Standards Committee B16 was reorganized as an ASME Committee operating under procedures accredited by ANSI. In ASME/ANSI B16.9-1986, the text was revised and inch dimensions were established as the standard.

In 1991, the Subcommittee reviewed the Standard and made a number of revisions that were included in ASME B16.9-1993. Dimensions for short pattern lap joints were also added.

In ASME B16.9-2001, short radius elbows and returns were added, which included all dimensions and tolerances of ASME B16.28-1994. Metric units were provided as an independent but parallel alternative standard to U.S. Customary units. U.S. Customary units were moved into parentheses or separate tables in Mandatory Appendix I. In addition, a Quality System Program appendix was added.

In 2003, the Subcommittee reviewed the Standard and made a number of revisions. The scope of the Standard was changed to permit fabricated lap joint stub ends employing circumferential or intersection welds.

In 2006, the Subcommittee reviewed the Standard and made a number of additions and revisions. Segmental elbow requirements were added, as were 3D radius elbow dimensions. Reference documents were updated.

In 2012, the Subcommittee reviewed the Standard and made numerous revisions to the design proof test in section 9 and updated the references in Mandatory Appendix II.

This edition adds more specific descriptions of acceptable design methods, revises the requirements for the design proof test, and updates the references. In addition, the U.S. Customary tables in Mandatory Appendix I have been merged with the Metric tables and all tables have been redesignated. Following the approval of the ASME B16 Standards Committee, ANSI approved ASME B16.9-2018 as an American National Standard on September 25, 2018.

ASME B16 COMMITTEE

Standardization of Valves, Flanges, Fittings, and Gaskets

(The following is the roster of the Committee at the time of approval of this Standard.)

STANDARDS COMMITTEE OFFICERS

R. M. Bojarczuk, *Chair*
C. E. Davila, *Vice Chair*
C. Ramcharran, *Secretary*

STANDARDS COMMITTEE PERSONNEL

A. Appleton , Alloy Stainless Products Co., Inc.	R. C. Merrick , Fluor Enterprises
J. E. Barker , Dezurik Water Controls	M. L. Nayyar , NICE
K. Barron , Ward Manufacturing	W. H. Patrick , The Dow Chemical Co.
D. C. Bayreuther , Metso Automation, Flow Control Division	D. Rahoi , CCM 2000
W. B. Bedesem , Consultant	C. Ramcharran , The American Society of Mechanical Engineers
R. M. Bojarczuk , Consultant	D. F. Reid , VSP Technologies
A. M. Cheta , Qatar Shell GTL	R. A. Schmidt , Canadoil
M. A. Clark , Consultant	J. P. Tucker , Flowserve Corp.
G. A. Cuccio , Capitol Manufacturing Co.	F. R. Volgstadt , Volgstadt & Associates, Inc.
J. D'Avanzo , Fluoroseal Valves	F. Feng , <i>Delegate</i> , China Productivity Center for Machinery
C. E. Davila , Crane Energy	R. W. Barnes , <i>Contributing Member</i> , Anric Enterprises, Inc.
K. S. Felder , Valero Energy	P. V. Craig , <i>Contributing Member</i> , Jomar Group
D. R. Frikken , Becht Engineering Co.	B. G. Fabian , <i>Contributing Member</i> , Pennsylvania Machine Works
D. Hunt, Jr. , Fastenal	M. Katcher , <i>Contributing Member</i> , Haynes International
G. A. Jolly , Samshin Ltd.	A. G. Kireta, Jr. , <i>Contributing Member</i> , Copper Development Association, Inc.
E. J. Lain , Exelon Nuclear	
T. A. McMahon , Emerson Process Management	

SUBCOMMITTEE F — STEEL THREADED AND WELDING FITTINGS

B. G. Fabian , <i>Chair</i> , Pennsylvania Machine Works	P. W. Heald , Bonney Forge
R. A. Schmidt , <i>Vice Chair</i> , Canadoil	D. Hunt, Jr. , Fastenal
E. Lawson , <i>Secretary</i> , The American Society of Mechanical Engineers	G. A. Jolly , Samshin Ltd.
J. Oh , <i>Secretary</i> , The American Society of Mechanical Engineers	G. Kavarana , CBI, Inc.
A. Appleton , Alloy Stainless Products Co., Inc.	W. Pritzl , Erne Fittings GmbH
G. A. Cuccio , Capitol Manufacturing Co.	J. P. Tucker , Flowserve Corp.
J. G. Dominguez , Welding Outlets, Inc.	G. T. Walden , Wolseley
K. W. Doughty , CB&I Alloy Piping Products	M. M. Zaidi , Jacobs Engineering Group, Inc.
J. P. Ellenberger	D. J. Lafferty , <i>Alternate</i> , US Drop Forge Co.
D. R. Frikken , Becht Engineering Co.	

CORRESPONDENCE WITH THE B16 COMMITTEE

General. ASME Standards are developed and maintained with the intent to represent the consensus of concerned interests. As such, users of this Standard may interact with the Committee by requesting interpretations, proposing revisions or a case, and attending Committee meetings. Correspondence should be addressed to:

Secretary, B16 Standards Committee
The American Society of Mechanical Engineers
Two Park Avenue
New York, NY 10016-5990
<http://go.asme.org/Inquiry>

Proposing Revisions. Revisions are made periodically to the Standard to incorporate changes that appear necessary or desirable, as demonstrated by the experience gained from the application of the Standard. Approved revisions will be published periodically.

The Committee welcomes proposals for revisions to this Standard. Such proposals should be as specific as possible, citing the paragraph number(s), the proposed wording, and a detailed description of the reasons for the proposal, including any pertinent documentation.

Proposing a Case. Cases may be issued to provide alternative rules when justified, to permit early implementation of an approved revision when the need is urgent, or to provide rules not covered by existing provisions. Cases are effective immediately upon ASME approval and shall be posted on the ASME Committee web page.

Requests for Cases shall provide a Statement of Need and Background Information. The request should identify the Standard and the paragraph, figure, or table number(s), and be written as a Question and Reply in the same format as existing Cases. Requests for Cases should also indicate the applicable edition(s) of the Standard to which the proposed Case applies.

Interpretations. Upon request, the B16 Standards Committee will render an interpretation of any requirement of the Standard. Interpretations can only be rendered in response to a written request sent to the Secretary of the B16 Standards Committee.

Requests for interpretation should preferably be submitted through the online Interpretation Submittal Form. The form is accessible at <http://go.asme.org/InterpretationRequest>. Upon submittal of the form, the Inquirer will receive an automatic e-mail confirming receipt.

If the Inquirer is unable to use the online form, he/she may e-mail the request to the Secretary of the B16 Standards Committee at SecretaryB16@asme.org, or mail it to the above address. The request for an interpretation should be clear and unambiguous. It is further recommended that the Inquirer submit his/her request in the following format:

Subject: Cite the applicable paragraph number(s) and the topic of the inquiry in one or two words.
Edition: Cite the applicable edition of the Standard for which the interpretation is being requested.
Question: Phrase the question as a request for an interpretation of a specific requirement suitable for general understanding and use, not as a request for an approval of a proprietary design or situation. Please provide a condensed and precise question, composed in such a way that a "yes" or "no" reply is acceptable.
Proposed Reply(ies): Provide a proposed reply(ies) in the form of "Yes" or "No," with explanation as needed. If entering replies to more than one question, please number the questions and replies.
Background Information: Provide the Committee with any background information that will assist the Committee in understanding the inquiry. The Inquirer may also include any plans or drawings that are necessary to explain the question; however, they should not contain proprietary names or information.

Requests that are not in the format described above may be rewritten in the appropriate format by the Committee prior to being answered, which may inadvertently change the intent of the original request.

Moreover, ASME does not act as a consultant for specific engineering problems or for the general application or understanding of the Standard requirements. If, based on the inquiry information submitted, it is the opinion of the Committee that the Inquirer should seek assistance, the inquiry will be returned with the recommendation that such assistance be obtained.

ASME procedures provide for reconsideration of any interpretation when or if additional information that might affect an interpretation is available. Further, persons aggrieved by an interpretation may appeal to the cognizant ASME Committee or Subcommittee. ASME does not “approve,” “certify,” “rate,” or “endorse” any item, construction, proprietary device, or activity.

Attending Committee Meetings. The B16 Standards Committee regularly holds meetings and/or telephone conferences that are open to the public. Persons wishing to attend any meeting and/or telephone conference should contact the Secretary of the B16 Standards Committee.

ASME B16.9-2018

SUMMARY OF CHANGES

Following approval by the ASME B16.9 Committee and ASME, and after public review, ASME B16.9-2018 was approved by the American National Standards Institute on September 29, 2018.

In ASME B16.9-2018, the U.S. Customary tables formerly in Mandatory Appendix I have been merged with the Metric tables in the main text; the tables have been redesignated, Mandatory Appendix I deleted, and the cross-references updated accordingly. In addition, this edition includes the following changes identified by a margin note, **(18)**. The Record Number listed below is explained in more detail in the “List of Changes in Record Number Order” following this Summary of Changes.

<i>Page</i>	<i>Location</i>	<i>Change (Record Number)</i>
1	1.4	First paragraph editorially revised
1	1.5.1	References to Mandatory Appendix II editorially revised
2	2.2	Revised in its entirety (17-1543)
3	Section 5	Revised (17-1543)
3	6.2.4	In subpara. (c), “3D” revised to “3D radius” (17-1543)
3	Section 9	Revised in its entirety (17-1543)
6	Table 5-1	Added (17-1543)
8	Table 6.1-2	Formerly Tables 2 and I-2; illustration within table revised (17-1543)
10	Table 6.1-5	Formerly Tables 5 and I-5; General Note editorially redesignated as Note (1), and Note reference added to the illustration
11	Table 6.1-6	Formerly Tables 6 and I-6; in title, “3D” revised to “3D Radius,” and in 45-deg elbow entry for NPS 30, “964” mm revised to “946” mm (17-1543)
23	Table 8-1	Formerly Table 12; Note (2) revised (17-1543)
24	Figure 8-1	Editorially redesignated from Figure 1
28	Mandatory Appendix I	Redesignated from Mandatory Appendix II and updated (17-1543)

LIST OF CHANGES IN RECORD NUMBER ORDER

<u>Record Number</u>	<u>Changes</u>
17-1543	Revised Table 6 title from "3D" to "3D Radius" in the Contents. Revised the Foreword. Revised section 2.2 in its entirety. Revised section 5. Revised "3D" to "3D radius" in section 6.2.4. Revised section 9 in its entirety. Replaced the figure in Tables 2 and I-2. Revised "3D" to "3D Radius" and "964" to "946" in Table 6. Revised the wording of Note (2) in Table 12. Revised "3D" to "3D Radius" in Table I-6. Made multiple revisions in Mandatory Appendix II.

FACTORY-MADE WROUGHT BUTTWELDING FITTINGS

1 SCOPE

1.1 General

This Standard covers overall dimensions, tolerances, ratings, testing, and markings for factory-made wrought butt welding fittings in sizes NPS $\frac{1}{2}$ through NPS 48 (DN 15 through DN 1200).

1.2 Special Fittings

Fittings may be made to special dimensions, sizes, shapes, and tolerances by agreement between the manufacturer and the purchaser.

1.3 Fabricated Fittings

Fabricated laterals and other fittings employing circumferential or intersection welds are considered pipe fabrication and are not within the scope of this Standard.

Fabricated lap joint stub ends are exempt from the above restrictions, provided they meet all the requirements of the applicable ASTM material specification listed in [section 5](#).

(18) 1.4 Relevant Units

This Standard states values in both SI (Metric) and U.S. Customary units. These systems of units are to be regarded separately as standard. Within the text and tables, the U.S. Customary units are shown in parentheses. The values stated in each system are not exact equivalents; therefore, it is required that each system of units be used independently of the other. Combining values from the two systems constitutes nonconformance with the Standard.

The designation for size is NPS for both Metric- and Customary-dimensioned fittings. Fitting pressure rating is associated with the connecting wall thickness of pipe of equivalent size and material.

1.5 References

- (18) **1.5.1 Referenced Standards.** Standards and specifications adopted by reference in this Standard are shown in [Mandatory Appendix I](#). It is not considered practical to identify the specific edition of each standard and specification in the individual references. Instead, the specific edition reference is identified in [Mandatory Appendix I](#). A product made in conformance with a prior edition of referenced standards and in all other respects conforming to this Standard will be considered to be in conformance.

1.5.2 Codes and Regulations. A fitting used under the jurisdiction of the ASME Boiler and Pressure Vessel Code (BPVC), the ASME Code for Pressure Piping, or a governmental regulation is subject to any limitation of that code or regulation. This includes any maximum temperature limitation or rule governing the use of a material at low temperature.

1.6 Service Conditions

Criteria for selection of fitting types and materials suitable for particular fluid service are not within the scope of this Standard.

1.7 Welding

Installation welding requirements are outside the scope of this Standard.

1.8 Quality Systems

Nonmandatory requirements relating to the fitting manufacturer's Quality System Program are described in [Nonmandatory Appendix A](#).

1.9 Convention

For determining conformance with this Standard, the convention for fixing significant digits where limits (maximum and minimum values) are specified shall be as defined in ASTM E29. This requires that an observed or calculated value be rounded off to the nearest unit in the last right-hand digit used for expressing the limit. Decimal values and tolerances do not imply a particular method of measurement.

1.10 Pressure Rating Designation

Class followed by a dimensionless number is the designation for pressure-temperature ratings. Standardized designations for flanges per ASME B16.5 referenced in this Standard are Classes 150, 300, 600, 900, 1500, and 2500.

2 PRESSURE RATINGS

2.1 Basis of Ratings

The allowable pressure ratings for fittings designed in accordance with this Standard may be calculated as for straight seamless pipe of equivalent material (as shown by comparison of composition and mechanical properties in the respective material specifications) in accordance with the rules established in the applicable sections of ASME B31, Code for Pressure Piping. For the calculation, applicable data for the pipe size, wall

thickness, and material that are equivalent to that of the fitting shall be used. Pipe size, wall thickness (or schedule number), and material identity on the fittings are in lieu of pressure rating markings.

(18) 2.2 Design of Fittings

2.2.1 Acceptable Design Methods. The design of fittings shall be established by one of the following methods:

(a) mathematical analyses contained in nationally recognized pressure vessel or piping codes (e.g., ASME B31.3 para. 304.2 for elbows and para. 304.3 for tees).

(b) proof testing in accordance with [section 9](#) of this Standard.

(c) experimental stress analysis, such as described in ASME BPVC, Section VIII, Division 2, Annex 5.F with validation of results. Hydrostatic testing can be used to validate experimental results.

(d) detailed stress analysis (e.g., finite element method) with results evaluated as described in ASME BPVC, Section VIII, Division 2, Part 5 with validation of results. Strain measurement, photoelastic testing, or hydrostatic testing can be used to validate calculated results.

2.2.2 Design Thickness. To meet design or manufacturing requirements, it is expected that some portion of formed fittings may have to be thicker than the pipe wall with which the fitting is intended to be used. The mathematical analyses, if used, may take into account such thicker sections.

2.2.3 Records. Copies of English-language records of the mathematical analysis, the successful proof test, or both shall be made available to the purchaser or regulatory authority upon request.

3 SIZE

NPS, followed by a dimensionless number, is the designation for nominal fitting size. NPS is related to the reference nominal diameter, DN, used in international standards. The relationship is, typically, as follows:

DN	NPS
15	$\frac{1}{2}$
20	$\frac{3}{4}$
25	1
32	$1\frac{1}{4}$
40	$1\frac{1}{2}$
50	2
65	$2\frac{1}{2}$
80	3
100	4

NOTE: For NPS > 4, the equivalence is DN = 25 × NPS.

4 MARKING

4.1 Standard Marking

Each fitting shall be permanently marked to show the following:

(a) manufacturer's name or trademark

(b) material identification, either the ASTM or ASME grade designation

(c) schedule number¹ or nominal wall thickness in mm

(d) size — the nominal pipe size (NPS) identification number related to the end connections shall be used

(e) compliance — see [para. 4.4](#) for standard and special fitting marking

A manufacturer may supplement these mandatory markings with others, including a DN size designation, but confusion with the required marking shall be avoided.

4.2 Exceptions

Where the size of the fitting does not permit complete marking, the identification marks may be omitted in reverse of the order presented in [para. 4.1](#).

4.3 Depth of Stamping

Where steel stamps are used, care shall be taken so that the marking is not deep enough or sharp enough to cause cracks or to reduce the wall thickness of the fitting below the minimum allowed.

4.4 Compliance

4.4.1 Standard Fittings. That the fitting was manufactured in conformance with this Standard, including all dimensional requirements, is certified by a prefix "WP" in the material grade designation marking.

4.4.2 Special Fittings. That the fitting was manufactured in conformance with this Standard, except that dimensional requirements are as agreed between the purchaser and the manufacturer, is certified by a supplementary suffix to the material grade designation marking as follows:

(a) "S58" of ASTM A960 applies for fittings in accordance with ASTM A234, ASTM A403, and ASTM A420.

(b) "S8" applies for fittings in accordance with ASTM A815.

(c) "SPLD" applies for fittings in accordance with ASTM B361, ASTM B363, and ASTM B366.

¹ Schedule number is a dimensionless number that is widely used as a convenient designation for use in ordering pipe and fittings. It is normally associated with a group of standardized pipe wall thicknesses. Refer to ASME B36.10M and ASME B36.19M for complete details on pipe schedule numbers.

(18) 5 MATERIAL

Wrought fittings covered by this Standard shall be in accordance with ASTM A234, ASTM A403, ASTM A420, ASTM A815, ASTM B361, ASTM B363, ASTM B366, or the corresponding specification listed in ASME BPVC, Section II. The term “wrought” denotes fittings made of pipe, tubing, plate, or forgings. For purposes of determining proof testing requirements of [section 9](#), the materials are grouped by similar properties as shown in [Table 5-1](#).

Fittings made from block forgings may only be supplied subject to agreement between the manufacturer and purchaser. Such fittings need not meet the requirements of [section 7](#).

6 FITTING DIMENSIONS**6.1 General**

This Standard provides for a fixed position for the welding ends with reference to either the centerline of the fittings or the overall dimensions. Dimensional requirements for these fittings are in [Tables 6.1-1](#) through [6.1-11](#).

6.2 Special Dimensions

6.2.1 Fatigue Loading. For applications where fatigue loading is a concern, required minimum dimensions shall be furnished by the purchaser.

6.2.2 Bore Diameter. Bore diameters away from the ends are not specified. If special flow path requirements are needed, the bore dimensions shall be specified by the purchaser.

6.2.3 Stub Ends. Service conditions and joint construction often dictate stub end length requirements. Therefore, the purchaser must specify long or short pattern fitting when ordering. [See General Note (b) in [Table 6.1-9](#).]

- (18) 6.2.4 Segmental Elbows.** Factory-made segments of short radius, long radius, and 3D radius elbows may be made to meet customer angle requirements. With the exception of the B dimension, factory-made segments of elbows shall meet all other requirements of this Standard. The B dimension for segmented elbows can be calculated as follows:

For segments of 90-deg elbows

$$B_s = A \times \tan(\theta/2)$$

where

A = dimension A for appropriate 90-deg elbow being segmented from

- (a) [Table 6.1-1](#) for long radius elbow, mm (in.)
- (b) [Table 6.1-4](#) for short radius elbow, mm (in.)
- (c) [Table 6.1-6](#) for 3D radius elbow, mm (in.)

B_s = center-to-end dimension for segmented elbow
 θ = angle of segmented elbow — 30 deg, 60 deg, 75 deg, etc.

When special elbows are intended for field segmenting, the outside or inside diameter tolerance shall be furnished throughout the fitting by agreement between the manufacturer and the purchaser. Any mismatch on the outside or inside diameter needs to be corrected in the field by grinding, back-welding, or bridging of weld to meet the applicable piping code requirements. Although the elbow intended for field segmenting must meet the requirements of this Standard, once the field-segmented elbow is cut, it is not a B16.9 product.

7 SURFACE CONTOURS

Where adjacent openings in fittings are not in parallel planes, they shall be joined by a circular arc or radius on the external surfaces. The arc or radius may be terminated in tangents. Except as provided for block forgings (see [section 5](#)), the projected profile of external surfaces of fittings shall not have sharp intersections (corners) and/or collapsed arcs.

8 END PREPARATION

Unless otherwise specified, the details of the welding end preparation shall be in accordance with [Table 8-1](#). Transitions from the welding bevel to the outside surface of the fitting and from the root face to the inside surface of the fitting lying within the maximum envelope shown in [Figure 8-1](#) are at the manufacturer's option, except as covered in Note (5) of [Figure 8-1](#) or unless otherwise specifically ordered.

9 DESIGN PROOF TEST

(18)

9.1 Required Tests

Proof tests shall be made as set forth in this Standard when the manufacturer chooses proof testing to qualify the fitting design. The pressure design thickness for critical areas of each type of fitting shall be determined and recorded. The design thickness for other sizes or wall thicknesses covered in [para. 9.4](#) shall require a similar percentage of reinforcement proportional by size or thickness. Critical areas are normally the inner radius of elbows, the crotch of tees and crosses, the knuckle radius of caps, and the large ends of reducers. Proof test shall be based on the computed burst pressure of the fitting and its connecting piping as defined in [para. 9.3](#).

9.2 Test Assembly

9.2.1 Representative Components. Each fitting type shall be tested, except that testing of certain types of fittings can qualify other fittings as described in [Table](#)

9.2.1-1. Fittings from the same material group that have the same basic design configuration and method of manufacture shall be selected from production for testing and shall be identified as to material, grade, and lot, including heat treatment.

(a) Examples of different basic configurations include the following:

(1) elbows of different centerline radius (short versus long versus 3D radius)

(2) tees or crosses formed in full encircling dies versus cold or hot extrusion using a pad die

(3) concentric versus eccentric shaped reducers

(4) caps of different configurations

(b) Examples of different methods of manufacture include the following:

(1) mandrel-formed elbows versus elbows welded from two half-shells versus bent pipe

(2) cold-formed tees or crosses versus extruded tees versus machined from solid forgings

(3) conical reducers versus bell-shaped (integral tangents) reducers

(4) caps formed by extruding through a draw ring versus ends cut off cold-formed tees versus machined from solids

(5) hot forming versus cold forming or using differential heating

9.2.2 Other Components. Straight seamless or welded pipe whose calculated bursting strength is at least as great as the proof test pressure as calculated in [para. 9.3](#) shall be welded to each end of the fitting to be tested. Pipe sections may have the nominal wall greater than the thickness indicated by the fitting markings. That greater thickness shall not exceed 1.5 times the fitting markings wall. Any internal misalignment greater than 1.5 mm (0.06 in.) shall be reduced by taper boring at a slope not greater than 1:3. Any other unequal wall welding preparation shall be in accordance with ASME B16.25. Length of pipe sections for closures shall be as follows:

(a) Minimum length of pipe shall be one pipe O.D. for NPS 14 (DN 350) and smaller.

(b) Minimum length of pipe shall be one-half pipe O.D. for NPS greater than 14 (DN 350).

9.3 Test Procedure

To qualify a fitting by proof testing, the fitting shall be tested as described herein and shall withstand the minimum calculated pressure for at least 180 s (3 min).

9.3.1 Number of Tests. At least three specimen tests for each fitting, joint size, or configuration are recommended. The test factor, f , is based on the number of specimen tests performed. The test factor, f , described in [Table 9.3.1-1](#), is used in the computed proof test pressure equation.

NOTE: Tests of geometrically identical fittings of different sizes and wall thicknesses that have overlapping ranges as described in [para. 9.4](#) may be combined to establish the test factor applied

to a set of fittings. For example, testing an NPS 2, NPS 8, and NPS 24 of the same basic design configuration and method of manufacture would qualify for a test factor of 1.0 and would qualify fittings of that type from NPS 1 to NPS 48 and thickness ranges in accordance with [para. 9.4.2](#).

9.3.2 Computed Test Pressure. The minimum proof test pressure shall be at least equal to the value computed by the following equation and rounded to the nearest 0.2 MPa (25 psi):

$$P = \frac{2Sft}{D}$$

where

D = specified outside diameter of pipe

f = test factor from [Table 9.3.1-1](#)

P = computed minimum proof test pressure for fitting

S = actual tensile strength of the test fitting, determined on a specimen representative of the test fitting, which shall meet the tensile strength requirements of the applicable material of [section 5](#)

t = nominal pipe wall thickness of the pipe that the fitting marking identifies

NOTE: Any dimensionally consistent system of units may be used.

9.3.3 Test Media. The test shall be conducted with water. Trapped air in the assembly shall be purged prior to the start of the test.

9.3.4 Application of Test Pressure. A pump with suitable pressure capacity shall be used to uniformly increase the test pressure through yield. Any gauges attached directly to the assembly may be removed and the pressure again uniformly increased at a suitable rate until either failure or the required test pressure has been achieved and held for 180 s. It is acceptable to increase pressure in the test assembly to accommodate reductions in test pressure caused by yielding in the test assembly.

9.3.5 Recording Pressure–Time Readings. Test pressure versus time readings shall be recorded periodically. This may be achieved through electronic means or instrumentation with appropriate resolution and range that has been calibrated prior to the test.

9.3.6 Test Temperature. The temperature(s) of the test fluid and components of the test assembly may not intentionally be increased or decreased if doing so would significantly affect a mechanical property or response of any component of the test assembly while it is under test.

9.3.7 Test Results. The test may be terminated if any component (e.g., fitting, pipe segment, fabrication weld) of the test assembly loses containment. The test of the fitting shall be considered unsuccessful if there is any loss of

containment from the tested fitting before or during the time it is to be held at or above the computed pressure. A proof test is successful only when the fitting being tested withstands for at least 180 s a continuous proof test pressure of at least the computed minimum (see [para. 9.3.2](#)) without exhibiting loss of containment or evidence of cracking, fissuring, tearing, etc. in the fitting under test.

9.4 Applicability of Test Results

It is not necessary to conduct an individual test of fittings with all combinations of sizes, wall thicknesses, and materials. A successful proof test on one representative fitting may qualify others to the extent described in [paras. 9.4.1, 9.4.2, and 9.4.3](#).

9.4.1 Size Range. One test fitting may be used to qualify similarly proportioned fittings as defined in [para. 9.2.1](#) with a size range from one-half to twice that for the tested fitting.

9.4.2 Thickness Range. One test fitting may be used to qualify similarly proportioned fittings as defined in [para. 9.2.1](#) with t/D ranges from one-half to three times that for the tested fitting.

9.4.3 Material Grades. The pressure-retaining capacity of a fitting of the same basic design configuration and method of manufacture made from material in a material group as listed in [Table 5-1](#) will be directly proportional to the tensile properties of the materials. Therefore, it is necessary to test only a representative fitting to prove the design of a fitting for all materials in a group.

9.5 Maintenance of Results

The manufacturer shall have a quality control (QC) program that verifies the manufacturing process and material used and ensures that the resulting geometry and design thickness of the fittings or joints manufactured reasonably conform to the geometries tested. The QC program shall control the manufacturing drawings and maintain the QC records showing conformance to these drawings.

Tests made in accordance with and at the time of previous editions of this Standard are not intended to be nullified by the changes made in this edition's test procedure and requirements, provided the design criteria for the type tested can be determined.

Whenever a significant change is made in the geometry or method of manufacture, the manufacturer shall either retest the new production or show by analysis that the change would not affect the results of prior tests. Examples of changes in geometry that require retests are a change in starting thickness or revised tooling configuration.

9.6 Proof Test Report

A report of the testing for each joint configuration shall be prepared and shall include

- (a) description of the test, including the number of tests and f factor used to establish the target proof test
- (b) instrumentation and methods of calibration used
- (c) material test reports for the assembly's materials (fitting, pipe, and end caps, if used)
- (d) actual final test pressures achieved for each test
- (e) length of time at or above the required test pressure (see [para. 9.3.4](#))
- (f) calculations performed
- (g) location of rupture, if any, including a sketch or photographs of the assembly
- (h) pressure design thickness required in critical areas
- (i) certification by the manufacturer and by a licensed Authorized Inspector or other third party having experience in pressure component design and testing

10 PRODUCTION TESTS

Hydrostatic testing of wrought fittings is not required by this Standard. All fittings shall be capable of withstanding, without leakage or impairment of serviceability, a hydrostatic test pressure required by the applicable piping code for seamless pipe of material equivalent to the fitting material, and of the size and wall thickness the fitting marking identifies.

11 TOLERANCES

Tolerances for fittings are shown in [Table 11-1](#) and apply to the nominal dimensions given in [Tables 6.1-1 through 6.1-11](#). Where given in the tables, the minimum and maximum dimensions are based on these tolerances. The listings with decimals do not imply precision measurement, such as use of vernier, micrometer, or electronic readout equipment.

(18)

Table 5-1 Material Groupings

Group No.	Material	Standards
1	Carbon and low-alloy steels	ASTM A234/A234M and ASTM A420/A420M
2	Austenitic and duplex stainless steels	ASTM A403/A403M and ASTM A815/A815M
3	Nickel alloys	ASTM B366/B366M
4	Aluminum alloys	ASTM B361
5	Titanium alloys	ASTM B363

Table 6.1-1 Dimensions of Long Radius Elbows

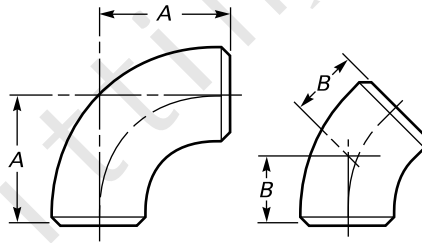

Nominal Pipe Size (NPS)	Outside Diameter at Bevel, mm (in.)	Center-to-End, mm (in.)	
		90-deg Elbows, A	45-deg Elbows, B
1/2	21.3 (0.84)	38 (1.50)	16 (0.62)
3/4	26.7 (1.05)	38 (1.50)	19 (0.75)
1	33.4 (1.32)	38 (1.50)	22 (0.88)
1 1/4	42.2 (1.66)	48 (1.88)	25 (1.00)
1 1/2	48.3 (1.90)	57 (2.25)	29 (1.12)
2	60.3 (2.38)	76 (3.00)	35 (1.38)
2 1/2	73.0 (2.88)	95 (3.75)	44 (1.75)
3	88.9 (3.50)	114 (4.50)	51 (2.00)
3 1/2	101.6 (4.00)	133 (5.25)	57 (2.25)
4	114.3 (4.50)	152 (6.00)	64 (2.50)
5	141.3 (5.56)	190 (7.50)	79 (3.12)
6	168.3 (6.62)	229 (9.00)	95 (3.75)
8	219.1 (8.62)	305 (12.00)	127 (5.00)
10	273.0 (10.75)	381 (15.00)	159 (6.25)
12	323.8 (12.75)	457 (18.00)	190 (7.50)
14	355.6 (14.00)	533 (21.00)	222 (8.75)
16	406.4 (16.00)	610 (24.00)	254 (10.00)
18	457.0 (18.00)	686 (27.00)	286 (11.25)
20	508.0 (20.00)	762 (30.00)	318 (12.50)
22	559.0 (22.00)	838 (33.00)	343 (13.50)
24	610.0 (24.00)	914 (36.00)	381 (15.00)
26	660.0 (26.00)	991 (39.00)	406 (16.00)
28	711.0 (28.00)	1 067 (42.00)	438 (17.25)
30	762.0 (30.00)	1 143 (45.00)	470 (18.50)
32	813.0 (32.00)	1 219 (48.00)	502 (19.75)
34	864.0 (34.00)	1 295 (51.00)	533 (21.00)
36	914.0 (36.00)	1 372 (54.00)	565 (22.25)
38	965.0 (38.00)	1 448 (57.00)	600 (23.62)
40	1 016.0 (40.00)	1 524 (60.00)	632 (24.88)
42	1 067.0 (42.00)	1 600 (63.00)	660 (26.00)
44	1 118.0 (44.00)	1 676 (66.00)	695 (27.38)
46	1 168.0 (46.00)	1 753 (69.00)	727 (28.62)
48	1 219.0 (48.00)	1 829 (72.00)	759 (29.88)

(18)

Table 6.1-2 Dimensions of Long Radius Reducing Elbows

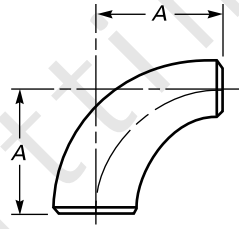

Nominal Pipe Size (NPS)	Outside Diameter at Bevel, mm (in.)		Center- to-End, A, mm (in.)	Nominal Pipe Size (NPS)	Outside Diameter at Bevel, mm (in.)		Center- to-End, A, mm (in.)
	Large End	Small End			Large End	Small End	
2 × 1½	60.3 (2.38)	48.3 (1.90)	76 (3.00)	10 × 8	273.0 (10.75)	219.1 (8.62)	381 (15.00)
2 × 1¼	60.3 (2.38)	42.2 (1.66)	76 (3.00)	10 × 6	273.0 (10.75)	168.3 (6.62)	381 (15.00)
2 × 1	60.3 (2.38)	33.4 (1.32)	76 (3.00)	10 × 5	273.0 (10.75)	141.3 (5.56)	381 (15.00)
2½ × 2	73.0 (2.88)	60.3 (2.38)	95 (3.75)	12 × 10	323.8 (12.75)	273.0 (10.75)	457 (18.00)
2½ × 1½	73.0 (2.88)	48.3 (1.90)	95 (3.75)	12 × 8	323.8 (12.75)	219.1 (8.62)	457 (18.00)
2½ × 1¼	73.0 (2.88)	42.2 (1.66)	95 (3.75)	12 × 6	323.8 (12.75)	168.3 (6.62)	457 (18.00)
3 × 2½	88.9 (3.50)	73.0 (2.88)	114 (4.50)	14 × 12	355.6 (14.00)	323.8 (12.75)	533 (21.00)
3 × 2	88.9 (3.50)	60.3 (2.38)	114 (4.50)	14 × 10	355.6 (14.00)	273.0 (10.75)	533 (21.00)
3 × 1½	88.9 (3.50)	48.3 (1.90)	114 (4.50)	14 × 8	355.6 (14.00)	219.1 (8.62)	533 (21.00)
3½ × 3	101.6 (4.00)	88.9 (3.50)	133 (5.25)	16 × 14	406.4 (16.00)	355.6 (14.00)	610 (24.00)
3½ × 2½	101.6 (4.00)	73.0 (2.88)	133 (5.25)	16 × 12	406.4 (16.00)	323.8 (12.75)	610 (24.00)
3½ × 2	101.6 (4.00)	60.3 (2.38)	133 (5.25)	16 × 10	406.4 (16.00)	273.0 (10.75)	610 (24.00)
4 × 3½	114.3 (4.50)	101.6 (4.00)	152 (6.00)	18 × 16	457.0 (18.00)	406.4 (16.00)	686 (27.00)
4 × 3	114.3 (4.50)	88.9 (3.50)	152 (6.00)	18 × 14	457.0 (18.00)	355.6 (14.00)	686 (27.00)
4 × 2½	114.3 (4.50)	73.0 (2.88)	152 (6.00)	18 × 12	457.0 (18.00)	323.8 (12.75)	686 (27.00)
4 × 2	114.3 (4.50)	60.3 (2.38)	152 (6.00)	18 × 10	457.0 (18.00)	273.0 (10.75)	686 (27.00)
5 × 4	141.3 (5.56)	114.3 (4.50)	190 (7.50)	20 × 18	508.0 (20.00)	457.0 (18.00)	762 (30.00)
5 × 3½	141.3 (5.56)	101.6 (4.00)	190 (7.50)	20 × 16	508.0 (20.00)	406.4 (16.00)	762 (30.00)
5 × 3	141.3 (5.56)	88.9 (3.50)	190 (7.50)	20 × 14	508.0 (20.00)	355.6 (14.00)	762 (30.00)
5 × 2½	141.3 (5.56)	73.0 (2.88)	190 (7.50)	20 × 12	508.0 (20.00)	323.8 (12.75)	762 (30.00)
				20 × 10	508.0 (20.00)	273.0 (10.75)	762 (30.00)
6 × 5	168.3 (6.62)	141.3 (5.56)	229 (9.00)	24 × 22	610.0 (24.00)	559.0 (22.00)	914 (36.00)
6 × 4	168.3 (6.62)	114.3 (4.50)	229 (9.00)	24 × 20	610.0 (24.00)	508.0 (20.00)	914 (36.00)
6 × 3½	168.3 (6.62)	101.6 (4.00)	229 (9.00)	24 × 18	610.0 (24.00)	457.0 (18.00)	914 (36.00)
6 × 3	168.3 (6.62)	88.9 (3.50)	229 (9.00)	24 × 16	610.0 (24.00)	406.4 (16.00)	914 (36.00)
8 × 6	219.1 (8.62)	168.3 (6.62)	305 (12.00)	24 × 14	610.0 (24.00)	355.6 (14.00)	914 (36.00)
8 × 5	219.1 (8.62)	141.3 (5.56)	305 (12.00)	24 × 12	610.0 (24.00)	323.8 (12.75)	914 (36.00)
8 × 4	219.1 (8.62)	114.3 (4.50)	305 (12.00)

Table 6.1-3 Dimensions of Long Radius Returns

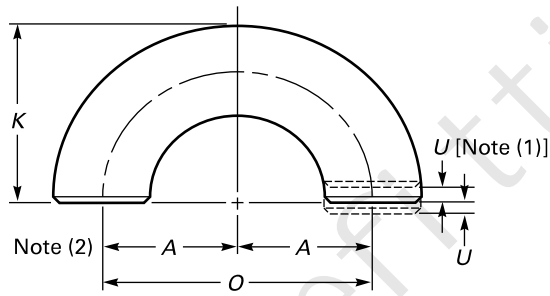

Nominal Pipe Size (NPS)	Outside Diameter at Bevel, mm (in.)	Center-to-Center, O, mm (in.)	Back-to-Face, K, mm (in.)
1/2	21.3 (0.84)	76 (3.00)	48 (1.88)
3/4	26.7 (1.05)	76 (3.00)	51 (2.00)
1	33.4 (1.32)	76 (3.00)	56 (2.19)
1 1/4	42.2 (1.66)	95 (3.75)	70 (2.75)
1 1/2	48.3 (1.90)	114 (4.50)	83 (3.25)
2	60.3 (2.38)	152 (6.00)	106 (4.19)
2 1/2	73.0 (2.88)	190 (7.50)	132 (5.19)
3	88.9 (3.50)	229 (9.00)	159 (6.25)
3 1/2	101.6 (4.00)	267 (10.50)	184 (7.25)
4	114.3 (4.50)	305 (12.00)	210 (8.25)
5	141.3 (5.56)	381 (15.00)	262 (10.31)
6	168.3 (6.62)	457 (18.00)	313 (12.31)
8	219.1 (8.62)	610 (24.00)	414 (16.31)
10	273.0 (10.75)	762 (30.00)	518 (20.38)
12	323.8 (12.75)	914 (36.00)	619 (24.38)
14	355.6 (14.00)	1 067 (42.00)	711 (28.00)
16	406.4 (16.00)	1 219 (48.00)	813 (32.00)
18	457.0 (18.00)	1 372 (54.00)	914 (36.00)
20	508.0 (20.00)	1 524 (60.00)	1 016 (40.00)
22	559.0 (22.00)	1 676 (66.00)	1 118 (44.00)
24	610.0 (24.00)	1 829 (72.00)	1 219 (48.00)

NOTES:

- (1) See Table 11-1 for tolerance for alignment of ends U.
- (2) Dimension A is equal to one-half of dimension O.

Table 6.1-4 Dimensions of Short Radius Elbows

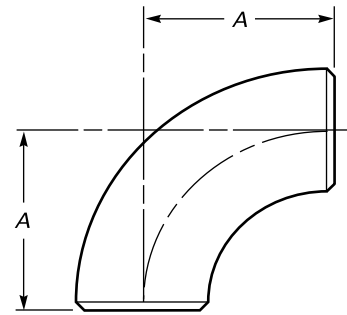

Nominal Pipe Size (NPS)	Outside Diameter at Bevel, mm (in.)	Center-to-End, A, mm (in.)
1	33.4 (1.32)	25 (1.00)
1 1/4	42.2 (1.66)	32 (1.25)
1 1/2	48.3 (1.90)	38 (1.50)
2	60.3 (2.38)	51 (2.00)
2 1/2	73.0 (2.88)	64 (2.50)
3	88.9 (3.50)	76 (3.00)
3 1/2	101.6 (4.00)	89 (3.50)
4	114.3 (4.50)	102 (4.00)
5	141.3 (5.56)	127 (5.00)
6	168.3 (6.62)	152 (6.00)
8	219.1 (8.62)	203 (8.00)
10	273.0 (10.75)	254 (10.00)
12	323.8 (12.75)	305 (12.00)
14	355.6 (14.00)	356 (14.00)
16	406.4 (16.00)	406 (16.00)
18	457.0 (18.00)	457 (18.00)
20	508.0 (20.00)	508 (20.00)
22	559.0 (22.00)	559 (22.00)
24	610.0 (24.00)	610 (24.00)

(18)

Table 6.1-5 Dimensions of Short Radius 180-deg Returns

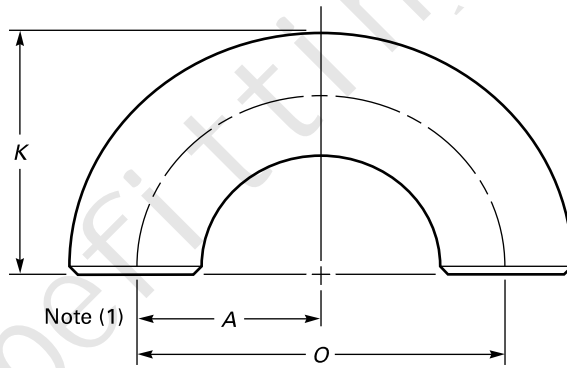

Nominal Pipe Size (NPS)	Outside Diameter at Bevel, mm (in.)	Center-to-Center, O, mm (in.)	Back-to-Face, K, mm (in.)
1	33.4 (1.32)	51 (2.00)	41 (1.62)
1 $\frac{1}{4}$	42.2 (1.66)	64 (2.50)	52 (2.06)
1 $\frac{1}{2}$	48.3 (1.90)	76 (3.00)	62 (2.44)
2	60.3 (2.38)	102 (4.00)	81 (3.19)
2 $\frac{1}{2}$	73.0 (2.88)	127 (5.00)	100 (3.94)
3	88.9 (3.50)	152 (6.00)	121 (4.75)
3 $\frac{1}{2}$	101.6 (4.00)	178 (7.00)	140 (5.50)
4	114.3 (4.50)	203 (8.00)	159 (6.25)
5	141.3 (5.56)	254 (10.00)	197 (7.75)
6	168.3 (6.62)	305 (12.00)	237 (9.31)
8	219.1 (8.62)	406 (16.00)	313 (12.31)
10	273.0 (10.75)	508 (20.00)	391 (15.38)
12	323.8 (12.75)	610 (24.00)	467 (18.38)
14	355.6 (14.00)	711 (28.00)	533 (21.00)
16	406.4 (16.00)	813 (32.00)	610 (24.00)
18	457.0 (18.00)	914 (36.00)	686 (27.00)
20	508.0 (20.00)	1 016 (40.00)	762 (30.00)
22	559.0 (22.00)	1 118 (44.00)	838 (33.00)
24	610.0 (24.00)	1 219 (48.00)	914 (36.00)

NOTE: (1) Dimension A is equal to one-half of dimension O.

(18)

Table 6.1-6 Dimensions of 3D Radius Elbows

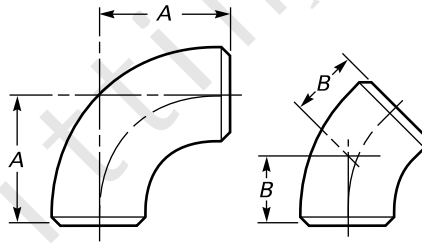

Nominal Pipe Size (NPS)	Outside Diameter at Bevel, mm (in.)	Center-to-End, mm (in.)	
		90-deg Elbows, A	45-deg Elbows, B
3/4	26.7 (1.05)	57 (2.25)	24 (0.94)
1	33.4 (1.32)	76 (3.00)	31 (1.25)
1 1/4	42.2 (1.66)	95 (3.75)	39 (1.56)
1 1/2	48.3 (1.90)	114 (4.50)	47 (1.88)
2	60.3 (2.38)	152 (6.00)	63 (2.50)
2 1/2	73.0 (2.88)	190 (7.50)	79 (3.12)
3	88.9 (3.50)	229 (9.00)	95 (3.75)
3 1/2	101.6 (4.00)	267 (10.50)	111 (4.38)
4	114.3 (4.50)	305 (12.00)	127 (5.00)
5	141.3 (5.56)	381 (15.00)	157 (6.19)
6	168.3 (6.62)	457 (18.00)	189 (7.44)
8	219.1 (8.62)	610 (24.00)	252 (9.94)
10	273.0 (10.75)	762 (30.00)	316 (12.44)
12	323.8 (12.75)	914 (36.00)	378 (14.88)
14	355.6 (14.00)	1 067 (42.00)	441 (17.38)
16	406.4 (16.00)	1 219 (48.00)	505 (19.88)
18	457.0 (18.00)	1 372 (54.00)	568 (22.38)
20	508.0 (20.00)	1 524 (60.00)	632 (24.88)
22	559.0 (22.00)	1 676 (66.00)	694 (27.31)
24	610.0 (24.00)	1 829 (72.00)	757 (29.81)
26	660.0 (26.00)	1 981 (78.00)	821 (32.31)
28	711.0 (28.00)	2 134 (84.00)	883 (34.75)
30	762.0 (30.00)	2 286 (90.00)	946 (37.25)
32	813.0 (32.00)	2 438 (96.00)	1 010 (39.75)
34	864.0 (34.00)	2 591 (102.00)	1 073 (42.25)
36	914.0 (36.00)	2 743 (108.00)	1 135 (44.69)
38	965.0 (38.00)	2 896 (114.00)	1 200 (47.25)
40	1 016.0 (40.00)	3 048 (120.00)	1 264 (49.75)
42	1 067.0 (42.00)	3 200 (126.00)	1 326 (52.19)
44	1 118.0 (44.00)	3 353 (132.00)	1 389 (54.69)
46	1 168.0 (46.00)	3 505 (138.00)	1 453 (57.19)
48	1 219.0 (48.00)	3 658 (144.00)	1 516 (59.69)

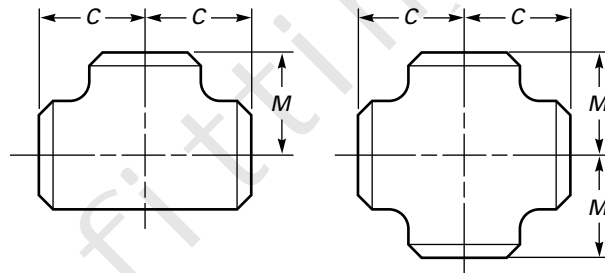
Table 6.1-7 Dimensions of Straight Tees and Crosses

Nominal Pipe Size (NPS)	Outside Diameter at Bevel, mm (in.)	Center-to-End, mm (in.)	
		Run, <i>C</i>	Outlet, <i>M</i> [Notes (1) and (2)]
1/2	21.3 (0.84)	25 (1.00)	25 (1.00)
3/4	26.7 (1.05)	29 (1.12)	29 (1.12)
1	33.4 (1.32)	38 (1.50)	38 (1.50)
1 1/4	42.2 (1.66)	48 (1.88)	48 (1.88)
1 1/2	48.3 (1.90)	57 (2.25)	57 (2.25)
2	60.3 (2.38)	64 (2.50)	64 (2.50)
2 1/2	73.0 (2.88)	76 (3.00)	76 (3.00)
3	88.9 (3.50)	86 (3.38)	86 (3.38)
3 1/2	101.6 (4.00)	95 (3.75)	95 (3.75)
4	114.3 (4.50)	105 (4.12)	105 (4.12)
5	141.3 (5.56)	124 (4.88)	124 (4.88)
6	168.3 (6.62)	143 (5.62)	143 (5.62)
8	219.1 (8.62)	178 (7.00)	178 (7.00)
10	273.0 (10.75)	216 (8.50)	216 (8.50)
12	323.8 (12.75)	254 (10.00)	254 (10.00)
14	355.6 (14.00)	279 (11.00)	279 (11.00)
16	406.4 (16.00)	305 (12.00)	305 (12.00)
18	457.0 (18.00)	343 (13.50)	343 (13.50)
20	508.0 (20.00)	381 (15.00)	381 (15.00)
22	559.0 (22.00)	419 (16.50)	419 (16.50)
24	610.0 (24.00)	432 (17.00)	432 (17.00)
26	660.0 (26.00)	495 (19.50)	495 (19.50)
28	711.0 (28.00)	521 (20.50)	521 (20.50)
30	762.0 (30.00)	559 (22.00)	559 (22.00)
32	813.0 (32.00)	597 (23.50)	597 (23.50)
34	864.0 (34.00)	635 (25.00)	635 (25.00)
36	914.0 (36.00)	673 (26.50)	673 (26.50)
38	965.0 (38.00)	711 (28.00)	711 (28.00)
40	1 016.0 (40.00)	749 (29.50)	749 (29.50)
42	1 067.0 (42.00)	762 (30.00)	711 (28.00)
44	1 118.0 (44.00)	813 (32.00)	762 (30.00)
46	1 168.0 (46.00)	851 (33.50)	800 (31.50)
48	1 219.0 (48.00)	889 (35.00)	838 (33.00)

NOTES:

- (1) Outlet dimension *M* for NPS 26 and larger is recommended but not required.
 (2) Dimensions applicable to crosses NPS 24 and smaller.

Table 6.1-8 Dimensions of Reducing Outlet Tees and Reducing Outlet Crosses

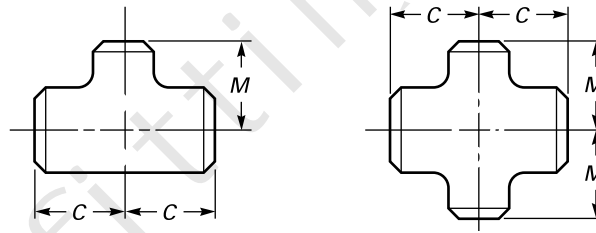

Nominal Pipe Size (NPS)	Outside Diameter at Bevel, mm (in.)		Center-to-End, mm (in.)	
	Run	Outlet	Run, C	Outlet, M [Note (1)]
1/2 x 1/2 x 3/8	21.3 (0.84)	17.3 (0.68)	25 (1.00)	25 (1.00)
1/2 x 1/2 x 1/4	21.3 (0.84)	13.7 (0.54)	25 (1.00)	25 (1.00)
3/4 x 3/4 x 1/2	26.7 (1.05)	21.3 (0.84)	29 (1.12)	29 (1.12)
3/4 x 3/4 x 3/8	26.7 (1.05)	17.3 (0.68)	29 (1.12)	29 (1.12)
1 x 1 x 3/4	33.4 (1.32)	26.7 (1.05)	38 (1.50)	38 (1.50)
1 x 1 x 1/2	33.4 (1.32)	21.3 (0.84)	38 (1.50)	38 (1.50)
1 1/4 x 1 1/4 x 1	42.2 (1.66)	33.4 (1.32)	48 (1.88)	48 (1.88)
1 1/4 x 1 1/4 x 3/4	42.2 (1.66)	26.7 (1.05)	48 (1.88)	48 (1.88)
1 1/4 x 1 1/4 x 1/2	42.2 (1.66)	21.3 (0.84)	48 (1.88)	48 (1.88)
1 1/2 x 1 1/2 x 1 1/4	48.3 (1.90)	42.2 (1.66)	57 (2.25)	57 (2.25)
1 1/2 x 1 1/2 x 1	48.3 (1.90)	33.4 (1.32)	57 (2.25)	57 (2.25)
1 1/2 x 1 1/2 x 3/4	48.3 (1.90)	26.7 (1.05)	57 (2.25)	57 (2.25)
1 1/2 x 1 1/2 x 1/2	48.3 (1.90)	21.3 (0.84)	57 (2.25)	57 (2.25)
2 x 2 x 1 1/2	60.3 (2.38)	48.3 (1.90)	64 (2.50)	60 (2.38)
2 x 2 x 1 1/4	60.3 (2.38)	42.2 (1.66)	64 (2.50)	57 (2.25)
2 x 2 x 1	60.3 (2.38)	33.4 (1.32)	64 (2.50)	51 (2.00)
2 x 2 x 3/4	60.3 (2.38)	26.7 (1.05)	64 (2.50)	44 (1.75)
2 1/2 x 2 1/2 x 2	73.0 (2.88)	60.3 (2.38)	76 (3.00)	70 (2.75)
2 1/2 x 2 1/2 x 1 1/2	73.0 (2.88)	48.3 (1.90)	76 (3.00)	67 (2.62)
2 1/2 x 2 1/2 x 1 1/4	73.0 (2.88)	42.2 (1.66)	76 (3.00)	64 (2.50)
2 1/2 x 2 1/2 x 1	73.0 (2.88)	33.4 (1.32)	76 (3.00)	57 (2.25)
3 x 3 x 2 1/2	88.9 (3.50)	73.0 (2.88)	86 (3.38)	83 (3.25)
3 x 3 x 2	88.9 (3.50)	60.3 (2.38)	86 (3.38)	76 (3.00)
3 x 3 x 1 1/2	88.9 (3.50)	48.3 (1.90)	86 (3.38)	73 (2.88)
3 x 3 x 1 1/4	88.9 (3.50)	42.2 (1.66)	86 (3.38)	70 (2.75)
3 1/2 x 3 1/2 x 3	101.6 (4.00)	88.9 (3.50)	95 (3.75)	92 (3.62)
3 1/2 x 3 1/2 x 2 1/2	101.6 (4.00)	73.0 (2.88)	95 (3.75)	89 (3.50)
3 1/2 x 3 1/2 x 2	101.6 (4.00)	60.3 (2.38)	95 (3.75)	83 (3.25)
3 1/2 x 3 1/2 x 1 1/2	101.6 (4.00)	48.3 (1.90)	95 (3.75)	79 (3.12)
4 x 4 x 3 1/2	114.3 (4.50)	101.6 (4.00)	105 (4.12)	102 (4.00)
4 x 4 x 3	114.3 (4.50)	88.9 (3.50)	105 (4.12)	98 (3.88)
4 x 4 x 2 1/2	114.3 (4.50)	73.0 (2.88)	105 (4.12)	95 (3.75)
4 x 4 x 2	114.3 (4.50)	60.3 (2.38)	105 (4.12)	89 (3.50)
4 x 4 x 1 1/2	114.3 (4.50)	48.3 (1.90)	105 (4.12)	86 (3.38)

Table 6.1-8 Dimensions of Reducing Outlet Tees and Reducing Outlet Crosses (Cont'd)

Nominal Pipe Size (NPS)	Outside Diameter at Bevel, mm (in.)		Center-to-End, mm (in.)	
	Run	Outlet	Run, <i>C</i>	Outlet, <i>M</i> [Note (1)]
5 × 5 × 4	141.3 (5.56)	114.3 (4.50)	124 (4.88)	117 (4.62)
5 × 5 × 3½	141.3 (5.56)	101.6 (4.00)	124 (4.88)	114 (4.50)
5 × 5 × 3	141.3 (5.56)	88.9 (3.50)	124 (4.88)	111 (4.38)
5 × 5 × 2½	141.3 (5.56)	73.0 (2.88)	124 (4.88)	108 (4.25)
5 × 5 × 2	141.3 (5.56)	60.3 (2.38)	124 (4.88)	105 (4.12)
6 × 6 × 5	168.3 (6.62)	141.3 (5.56)	143 (5.62)	137 (5.38)
6 × 6 × 4	168.3 (6.62)	114.3 (4.50)	143 (5.62)	130 (5.12)
6 × 6 × 3½	168.3 (6.62)	101.6 (4.00)	143 (5.62)	127 (5.00)
6 × 6 × 3	168.3 (6.62)	88.9 (3.50)	143 (5.62)	124 (4.88)
6 × 6 × 2½	168.3 (6.62)	73.0 (2.88)	143 (5.62)	121 (4.75)
8 × 8 × 6	219.1 (8.62)	168.3 (6.62)	178 (7.00)	168 (6.62)
8 × 8 × 5	219.1 (8.62)	141.3 (5.56)	178 (7.00)	162 (6.38)
8 × 8 × 4	219.1 (8.62)	114.3 (4.50)	178 (7.00)	156 (6.12)
8 × 8 × 3½	219.1 (8.62)	101.6 (4.00)	178 (7.00)	152 (6.00)
10 × 10 × 8	273.0 (10.75)	219.1 (8.62)	216 (8.50)	203 (8.00)
10 × 10 × 6	273.0 (10.75)	168.3 (6.62)	216 (8.50)	194 (7.62)
10 × 10 × 5	273.0 (10.75)	141.3 (5.56)	216 (8.50)	191 (7.50)
10 × 10 × 4	273.0 (10.75)	114.3 (4.50)	216 (8.50)	184 (7.25)
12 × 12 × 10	323.8 (12.75)	273.0 (10.75)	254 (10.00)	241 (9.50)
12 × 12 × 8	323.8 (12.75)	219.1 (8.62)	254 (10.00)	229 (9.00)
12 × 12 × 6	323.8 (12.75)	168.3 (6.62)	254 (10.00)	219 (8.62)
12 × 12 × 5	323.8 (12.75)	141.3 (5.56)	254 (10.00)	216 (8.50)
14 × 14 × 12	355.6 (14.00)	323.8 (12.75)	279 (11.00)	270 (10.62)
14 × 14 × 10	355.6 (14.00)	273.0 (10.75)	279 (11.00)	257 (10.12)
14 × 14 × 8	355.6 (14.00)	219.1 (8.62)	279 (11.00)	248 (9.75)
14 × 14 × 6	355.6 (14.00)	168.3 (6.62)	279 (11.00)	238 (9.38)
16 × 16 × 14	406.4 (16.00)	355.6 (14.00)	305 (12.00)	305 (12.00)
16 × 16 × 12	406.4 (16.00)	323.8 (12.75)	305 (12.00)	295 (11.62)
16 × 16 × 10	406.4 (16.00)	273.0 (10.75)	305 (12.00)	283 (11.12)
16 × 16 × 8	406.4 (16.00)	219.1 (8.62)	305 (12.00)	273 (10.75)
16 × 16 × 6	406.4 (16.00)	168.3 (6.62)	305 (12.00)	264 (10.38)
18 × 18 × 16	457 (18.00)	406.4 (16.00)	343 (13.50)	330 (13.00)
18 × 18 × 14	457 (18.00)	355.6 (14.00)	343 (13.50)	330 (13.00)
18 × 18 × 12	457 (18.00)	323.8 (12.75)	343 (13.50)	321 (12.62)
18 × 18 × 10	457 (18.00)	273.0 (10.75)	343 (13.50)	308 (12.12)
18 × 18 × 8	457 (18.00)	219.1 (8.62)	343 (13.50)	298 (11.75)
20 × 20 × 18	508 (20.00)	457.0 (18.00)	381 (15.00)	368 (14.50)
20 × 20 × 16	508 (20.00)	406.4 (16.00)	381 (15.00)	356 (14.00)
20 × 20 × 14	508 (20.00)	355.6 (14.00)	381 (15.00)	356 (14.00)

Table 6.1-8 Dimensions of Reducing Outlet Tees and Reducing Outlet Crosses (Cont'd)

Nominal Pipe Size (NPS)	Outside Diameter at Bevel, mm (in.)		Center-to-End, mm (in.)	
	Run	Outlet	Run, C	Outlet, M [Note (1)]
20 × 20 × 12	508 (20.00)	323.8 (12.75)	381 (15.00)	346 (13.62)
20 × 20 × 10	508 (20.00)	273.0 (10.75)	381 (15.00)	333 (13.12)
20 × 20 × 8	508 (20.00)	219.1 (8.62)	381 (15.00)	324 (12.75)
22 × 22 × 20	559 (22.00)	508.0 (20.00)	419 (16.50)	406 (16.00)
22 × 22 × 18	559 (22.00)	457.0 (18.00)	419 (16.50)	394 (15.50)
22 × 22 × 16	559 (22.00)	406.4 (16.00)	419 (16.50)	381 (15.00)
22 × 22 × 14	559 (22.00)	355.6 (14.00)	419 (16.50)	381 (15.00)
22 × 22 × 12	559 (22.00)	323.8 (12.75)	419 (16.50)	371 (14.62)
22 × 22 × 10	559 (22.00)	273.0 (10.75)	419 (16.50)	359 (14.12)
24 × 24 × 22	610 (24.00)	559.0 (22.00)	432 (17.00)	432 (17.00)
24 × 24 × 20	610 (24.00)	508.0 (20.00)	432 (17.00)	432 (17.00)
24 × 24 × 18	610 (24.00)	457.0 (18.00)	432 (17.00)	419 (16.50)
24 × 24 × 16	610 (24.00)	406.4 (16.00)	432 (17.00)	406 (16.00)
24 × 24 × 14	610 (24.00)	355.6 (14.00)	432 (17.00)	406 (16.00)
24 × 24 × 12	610 (24.00)	323.8 (12.75)	432 (17.00)	397 (15.62)
24 × 24 × 10	610 (24.00)	273.0 (10.75)	432 (17.00)	384 (15.12)
26 × 26 × 24	660 (26.00)	610.0 (24.00)	495 (19.50)	483 (19.00)
26 × 26 × 22	660 (26.00)	559.0 (22.00)	495 (19.50)	470 (18.50)
26 × 26 × 20	660 (26.00)	508.0 (20.00)	495 (19.50)	457 (18.00)
26 × 26 × 18	660 (26.00)	457.0 (18.00)	495 (19.50)	444 (17.50)
26 × 26 × 16	660 (26.00)	406.4 (16.00)	495 (19.50)	432 (17.00)
26 × 26 × 14	660 (26.00)	355.6 (14.00)	495 (19.50)	432 (17.00)
26 × 26 × 12	660 (26.00)	323.8 (12.75)	495 (19.50)	422 (16.62)
28 × 28 × 26	711 (28.00)	660.0 (26.00)	521 (20.50)	521 (20.50)
28 × 28 × 24	711 (28.00)	610.0 (24.00)	521 (20.50)	508 (20.00)
28 × 28 × 22	711 (28.00)	559.0 (22.00)	521 (20.50)	495 (19.50)
28 × 28 × 20	711 (28.00)	508.0 (20.00)	521 (20.50)	483 (19.00)
28 × 28 × 18	711 (28.00)	457.0 (18.00)	521 (20.50)	470 (18.50)
28 × 28 × 16	711 (28.00)	406.4 (16.00)	521 (20.50)	457 (18.00)
28 × 28 × 14	711 (28.00)	355.6 (14.00)	521 (20.50)	457 (18.00)
28 × 28 × 12	711 (28.00)	323.8 (12.75)	521 (20.50)	448 (17.62)
30 × 30 × 28	762 (30.00)	711.0 (28.00)	559 (22.00)	546 (21.50)
30 × 30 × 26	762 (30.00)	660.0 (26.00)	559 (22.00)	546 (21.50)
30 × 30 × 24	762 (30.00)	610.0 (24.00)	559 (22.00)	533 (21.00)
30 × 30 × 22	762 (30.00)	559.0 (22.00)	559 (22.00)	521 (20.50)
30 × 30 × 20	762 (30.00)	508.0 (20.00)	559 (22.00)	508 (20.00)
30 × 30 × 18	762 (30.00)	457.0 (18.00)	559 (22.00)	495 (19.50)
30 × 30 × 16	762 (30.00)	406.4 (16.00)	559 (22.00)	483 (19.00)
30 × 30 × 14	762 (30.00)	355.6 (14.00)	559 (22.00)	483 (19.00)

Table 6.1-8 Dimensions of Reducing Outlet Tees and Reducing Outlet Crosses (Cont'd)

Nominal Pipe Size (NPS)	Outside Diameter at Bevel, mm (in.)		Center-to-End, mm (in.)	
	Run	Outlet	Run, <i>C</i>	Outlet, <i>M</i> [Note (1)]
30 × 30 × 12	762 (30.00)	323.8 (12.75)	559 (22.00)	473 (18.62)
30 × 30 × 10	762 (30.00)	273.0 (10.75)	559 (22.00)	460 (18.12)
32 × 32 × 30	813 (32.00)	762.0 (30.00)	597 (23.50)	584 (23.00)
32 × 32 × 28	813 (32.00)	711.0 (28.00)	597 (23.50)	572 (22.5)
32 × 32 × 26	813 (32.00)	660.0 (26.00)	597 (23.50)	572 (22.50)
32 × 32 × 24	813 (32.00)	610.0 (24.00)	597 (23.50)	559 (22.00)
32 × 32 × 22	813 (32.00)	559.0 (22.00)	597 (23.50)	546 (21.50)
32 × 32 × 20	813 (32.00)	508.0 (20.00)	597 (23.50)	533 (21.00)
32 × 32 × 18	813 (32.00)	457.0 (18.00)	597 (23.50)	521 (20.50)
32 × 32 × 16	813 (32.00)	406.4 (16.00)	597 (23.50)	508 (20.00)
32 × 32 × 14	813 (32.00)	355.6 (14.00)	597 (23.50)	508 (20.00)
34 × 34 × 32	864 (34.00)	813.0 (32.00)	635 (25.00)	622 (24.50)
34 × 34 × 30	864 (34.00)	762.0 (30.00)	635 (25.00)	610 (24.00)
34 × 34 × 28	864 (34.00)	711.0 (28.00)	635 (25.00)	597 (23.50)
34 × 34 × 26	864 (34.00)	660.0 (26.00)	635 (25.00)	597 (23.50)
34 × 34 × 24	864 (34.00)	610.0 (24.00)	635 (25.00)	584 (23.00)
34 × 34 × 22	864 (34.00)	559.0 (22.00)	635 (25.00)	572 (22.50)
34 × 34 × 20	864 (34.00)	508.0 (20.00)	635 (25.00)	559 (22.00)
34 × 34 × 18	864 (34.00)	457.0 (18.00)	635 (25.00)	546 (21.50)
34 × 34 × 16	864 (34.00)	406.4 (16.00)	635 (25.00)	533 (21.00)
36 × 36 × 34	914 (36.00)	864.0 (34.00)	673 (26.50)	660 (26.00)
36 × 36 × 32	914 (36.00)	813.0 (32.00)	673 (26.50)	648 (25.50)
36 × 36 × 30	914 (36.00)	762.0 (30.00)	673 (26.50)	635 (25.00)
36 × 36 × 28	914 (36.00)	711.0 (28.00)	673 (26.50)	622 (24.50)
36 × 36 × 26	914 (36.00)	660.0 (26.00)	673 (26.50)	622 (24.50)
36 × 36 × 24	914 (36.00)	610.0 (24.00)	673 (26.50)	610 (24.00)
36 × 36 × 22	914 (36.00)	559.0 (22.00)	673 (26.50)	597 (23.50)
36 × 36 × 20	914 (36.00)	508.0 (20.00)	673 (26.50)	584 (23.00)
36 × 36 × 18	914 (36.00)	457.0 (18.00)	673 (26.50)	572 (22.50)
36 × 36 × 16	914 (36.00)	406.4 (16.00)	673 (26.50)	559 (22.00)
38 × 38 × 36	965 (38.00)	914.0 (36.00)	711 (28.00)	711 (28.00)
38 × 38 × 34	965 (38.00)	864.0 (34.00)	711 (28.00)	698 (27.50)
38 × 38 × 32	965 (38.00)	813.0 (32.00)	711 (28.00)	686 (27.00)
38 × 38 × 30	965 (38.00)	762.0 (30.00)	711 (28.00)	673 (26.50)
38 × 38 × 28	965 (38.00)	711.0 (28.00)	711 (28.00)	648 (25.50)
38 × 38 × 26	965 (38.00)	660.0 (26.00)	711 (28.00)	648 (25.50)
38 × 38 × 24	965 (38.00)	610.0 (24.00)	711 (28.00)	635 (25.00)
38 × 38 × 22	965 (38.00)	559.0 (22.00)	711 (28.00)	622 (24.50)
38 × 38 × 20	965 (38.00)	508.0 (20.00)	711 (28.00)	610 (24.00)
38 × 38 × 18	965 (38.00)	457.0 (18.00)	711 (28.00)	597 (23.50)

Table 6.1-8 Dimensions of Reducing Outlet Tees and Reducing Outlet Crosses (Cont'd)

Nominal Pipe Size (NPS)	Outside Diameter at Bevel, mm (in.)		Center-to-End, mm (in.)	
	Run	Outlet	Run, C	Outlet, M [Note (1)]
40 × 40 × 38	1 016 (40.00)	965.0 (38.00)	749 (29.50)	749 (29.50)
40 × 40 × 36	1 016 (40.00)	914.0 (36.00)	749 (29.50)	737 (29.00)
40 × 40 × 34	1 016 (40.00)	864.0 (34.00)	749 (29.50)	724 (28.50)
40 × 40 × 32	1 016 (40.00)	813.0 (32.00)	749 (29.50)	711 (28.00)
40 × 40 × 30	1 016 (40.00)	762.0 (30.00)	749 (29.50)	698 (27.50)
40 × 40 × 28	1 016 (40.00)	711.0 (28.00)	749 (29.50)	673 (26.50)
40 × 40 × 26	1 016 (40.00)	660.0 (26.00)	749 (29.50)	673 (26.50)
40 × 40 × 24	1 016 (40.00)	610.0 (24.00)	749 (29.50)	660 (26.00)
40 × 40 × 22	1 016 (40.00)	559.0 (22.00)	749 (29.50)	648 (25.50)
40 × 40 × 20	1 016 (40.00)	508.0 (20.00)	749 (29.50)	635 (25.00)
40 × 40 × 18	1 016 (40.00)	457.0 (18.00)	749 (29.50)	622 (24.50)
42 × 42 × 40	1 067 (42.00)	1 016.0 (40.00)	762 (30.00)	711 (28.00)
42 × 42 × 38	1 067 (42.00)	965.0 (38.00)	762 (30.00)	711 (28.00)
42 × 42 × 36	1 067 (42.00)	914.0 (36.00)	762 (30.00)	711 (28.00)
42 × 42 × 34	1 067 (42.00)	864.0 (34.00)	762 (30.00)	711 (28.00)
42 × 42 × 32	1 067 (42.00)	813.0 (32.00)	762 (30.00)	711 (28.00)
42 × 42 × 30	1 067 (42.00)	762.0 (30.00)	762 (30.00)	711 (28.00)
42 × 42 × 28	1 067 (42.00)	711.0 (28.00)	762 (30.00)	698 (27.50)
42 × 42 × 26	1 067 (42.00)	660.0 (26.00)	762 (30.00)	698 (27.50)
42 × 42 × 24	1 067 (42.00)	610.0 (24.00)	762 (30.00)	660 (26.00)
42 × 42 × 22	1 067 (42.00)	559.0 (22.00)	762 (30.00)	660 (26.00)
42 × 42 × 20	1 067 (42.00)	508.0 (20.00)	762 (30.00)	660 (26.00)
42 × 42 × 18	1 067 (42.00)	457.0 (18.00)	762 (30.00)	648 (25.50)
42 × 42 × 16	1 067 (42.00)	406.4 (16.00)	762 (30.00)	635 (25.00)
44 × 44 × 42	1 118 (44.00)	1 067.0 (42.00)	813 (32.00)	762 (30.00)
44 × 44 × 40	1 118 (44.00)	1 016.0 (40.00)	813 (32.00)	749 (29.50)
44 × 44 × 38	1 118 (44.00)	965.0 (38.00)	813 (32.00)	737 (29.00)
44 × 44 × 36	1 118 (44.00)	914.0 (36.00)	813 (32.00)	724 (28.50)
44 × 44 × 34	1 118 (44.00)	864.0 (34.00)	813 (32.00)	724 (28.50)
44 × 44 × 32	1 118 (44.00)	813.0 (32.00)	813 (32.00)	711 (28.00)
44 × 44 × 30	1 118 (44.00)	762.0 (30.00)	813 (32.00)	711 (28.00)
44 × 44 × 28	1 118 (44.00)	711.0 (28.00)	813 (32.00)	698 (27.50)
44 × 44 × 26	1 118 (44.00)	660.0 (26.00)	813 (32.00)	698 (27.50)
44 × 44 × 24	1 118 (44.00)	610.0 (24.00)	813 (32.00)	698 (27.50)
44 × 44 × 22	1 118 (44.00)	559.0 (22.00)	813 (32.00)	686 (27.00)
44 × 44 × 20	1 118 (44.00)	508.0 (20.00)	813 (32.00)	686 (27.00)
46 × 46 × 44	1 168 (46.00)	1 118.0 (44.00)	851 (33.50)	800 (31.50)
46 × 46 × 42	1 168 (46.00)	1 067.0 (42.00)	851 (33.50)	787 (31.00)
46 × 46 × 40	1 168 (46.00)	1 016.0 (40.00)	851 (33.50)	775 (30.50)
46 × 46 × 38	1 168 (46.00)	965.0 (38.00)	851 (33.50)	762 (30.00)

Table 6.1-8 Dimensions of Reducing Outlet Tees and Reducing Outlet Crosses (Cont'd)

Nominal Pipe Size (NPS)	Outside Diameter at Bevel, mm (in.)		Center-to-End, mm (in.)	
	Run	Outlet	Run, <i>C</i>	Outlet, <i>M</i> [Note (1)]
46 × 46 × 36	1 168 (46.00)	914.0 (36.00)	851 (33.50)	762 (30.00)
46 × 46 × 34	1 168 (46.00)	864.0 (34.00)	851 (33.50)	749 (29.50)
46 × 46 × 32	1 168 (46.00)	813.0 (32.00)	851 (33.50)	749 (29.50)
46 × 46 × 30	1 168 (46.00)	762.0 (30.00)	851 (33.50)	737 (29.00)
46 × 46 × 28	1 168 (46.00)	711.0 (28.00)	851 (33.50)	737 (29.00)
46 × 46 × 26	1 168 (46.00)	660.0 (26.00)	851 (33.50)	737 (29.00)
46 × 46 × 24	1 168 (46.00)	610.0 (24.00)	851 (33.50)	724 (28.50)
46 × 46 × 22	1 168 (46.00)	559.0 (22.00)	851 (33.50)	724 (28.50)
48 × 48 × 46	1 219 (48.00)	1 168.0 (46.00)	889 (35.00)	838 (33.00)
48 × 48 × 44	1 219 (48.00)	1 118.0 (44.00)	889 (35.00)	838 (33.00)
48 × 48 × 42	1 219 (48.00)	1 067.0 (42.00)	889 (35.00)	813 (32.00)
48 × 48 × 40	1 219 (48.00)	1 016.0 (40.00)	889 (35.00)	813 (32.00)
48 × 48 × 38	1 219 (48.00)	965.0 (38.00)	889 (35.00)	813 (32.00)
48 × 48 × 36	1 219 (48.00)	914.0 (36.00)	889 (35.00)	787 (31.00)
48 × 48 × 34	1 219 (48.00)	864.0 (34.00)	889 (35.00)	787 (31.00)
48 × 48 × 32	1 219 (48.00)	813.0 (32.00)	889 (35.00)	787 (31.00)
48 × 48 × 30	1 219 (48.00)	762.0 (30.00)	889 (35.00)	762 (30.00)
48 × 48 × 28	1 219 (48.00)	711.0 (28.00)	889 (35.00)	762 (30.00)
48 × 48 × 26	1 219 (48.00)	660.0 (26.00)	889 (35.00)	762 (30.00)
48 × 48 × 24	1 219 (48.00)	610.0 (24.00)	889 (35.00)	737 (29.00)
48 × 48 × 22	1 219 (48.00)	559.0 (22.00)	889 (35.00)	737 (29.00)

NOTE: (1) Outlet dimension *M* for run sizes NPS 14 and larger is recommended but not required.

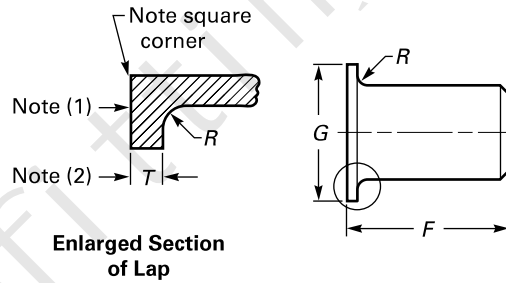
Table 6.1-9 Dimensions of Lap Joint Stub Ends

Nominal Pipe Size (NPS)	Outside Diameter of Barrel, mm (in.)		Long Pattern Length, F , mm (in.)	Short Pattern Length, F , mm (in.)	Radius of Fillet, R , mm (in.)	Diameter of Lap, G , mm (in.)
	Max.	Min.	[Notes (3), (4)]	[Notes (3), (4)]	[Note (5)]	[Note (6)]
1/2	22.8 (0.896)	20.5 (0.809)	76 (3.00)	51 (2.00)	3 (0.12)	35 (1.38)
3/4	28.1 (1.106)	25.9 (1.019)	76 (3.00)	51 (2.00)	3 (0.12)	43 (1.69)
1	35.0 (1.376)	32.6 (1.284)	102 (4.00)	51 (2.00)	3 (0.12)	51 (2.00)
1 1/4	43.6 (1.716)	41.4 (1.629)	102 (4.00)	51 (2.00)	5 (0.19)	64 (2.50)
1 1/2	49.9 (1.965)	47.5 (1.869)	102 (4.00)	51 (2.00)	6 (0.25)	73 (2.88)
2	62.4 (2.456)	59.5 (2.344)	152 (6.00)	64 (2.50)	8 (0.31)	92 (3.62)
2 1/2	75.3 (2.966)	72.2 (2.844)	152 (6.00)	64 (2.50)	8 (0.31)	105 (4.12)
3	91.3 (3.596)	88.1 (3.469)	152 (6.00)	64 (2.50)	10 (0.38)	127 (5.00)
3 1/2	104.0 (4.096)	100.8 (3.969)	152 (6.00)	76 (3.00)	10 (0.38)	140 (5.50)
4	116.7 (4.593)	113.5 (4.469)	152 (6.00)	76 (3.00)	11 (0.44)	157 (6.19)
5	144.3 (5.683)	140.5 (5.532)	203 (8.00)	76 (3.00)	11 (0.44)	186 (7.31)
6	171.3 (6.743)	167.5 (6.594)	203 (8.00)	89 (3.50)	13 (0.50)	216 (8.50)
8	222.1 (8.743)	218.3 (8.594)	203 (8.00)	102 (4.00)	13 (0.50)	270 (10.62)
10	277.2 (10.913)	272.3 (10.719)	254 (10.00)	127 (5.00)	13 (0.50)	324 (12.75)
12	328.0 (12.913)	323.1 (12.719)	254 (10.00)	152 (6.00)	13 (0.50)	381 (15.00)
14	359.9 (14.170)	354.8 (13.969)	305 (12.00)	152 (6.00)	13 (0.50)	413 (16.25)
16	411.0 (16.180)	405.6 (15.969)	305 (12.00)	152 (6.00)	13 (0.50)	470 (18.50)
18	462.0 (18.190)	456.0 (17.969)	305 (12.00)	152 (6.00)	13 (0.50)	533 (21.00)
20	514.0 (20.240)	507.0 (19.969)	305 (12.00)	152 (6.00)	13 (0.50)	584 (23.00)
22	565.0 (22.240)	558.0 (21.969)	305 (12.00)	152 (6.00)	13 (0.50)	641 (25.25)
24	616.0 (24.240)	609.0 (23.969)	305 (12.00)	152 (6.00)	13 (0.50)	692 (27.25)

GENERAL NOTES:

- (a) See Table 11-1 for tolerances.
 (b) Service conditions and joint construction often dictate stub end length requirements. Therefore, the purchaser must specify long or short pattern fitting when ordering.

NOTES:

- (1) Gasket face finish shall be in accordance with ASME B16.5 for raised-face flanges.
 (2) The lap thickness, T , shall not be less than nominal pipe wall thickness. See Table 11-1 for tolerance.
 (3) When short pattern stub ends are used with larger flanges in Classes 300 and 600, with most sizes in Classes 900 and higher, and when long pattern stub ends are used with larger flanges in Classes 1500 and 2500, it may be necessary to increase the length of the stub ends in order to avoid covering the weld with the flange. Such increases in length shall be a matter of agreement between the manufacturer and purchaser.
 (4) When special facings such as tongue and groove or male and female are employed, additional lap thickness must be provided and such additional thickness shall be in addition to (not included in) the basic length, F .
 (5) These dimensions conform to the radius established for lap joint flanges in ASME B16.5.
 (6) This dimension conforms to standard machined facings shown in ASME B16.5. The back face of the lap shall be machined to conform to the surface on which it sits. Where ring joint facings are to be applied, use dimension K as given in ASME B16.5.

Table 6.1-10 Dimensions of Caps

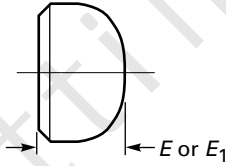

Nominal Pipe Size (NPS)	Outside Diameter at Bevel, mm (in.)	Length, E, mm (in.) [Note (1)]	Limiting Wall Thickness for Length, E, mm (in.)	Length, E ₁ , mm (in.) [Note (2)]
1/2	21.3 (0.84)	25 (1.00)	4.57 (0.18)	25 (1.00)
3/4	26.7 (1.05)	25 (1.00)	3.81 (0.15)	25 (1.00)
1	33.4 (1.32)	38 (1.50)	4.57 (0.18)	38 (1.50)
1 1/4	42.2 (1.66)	38 (1.50)	4.83 (0.19)	38 (1.50)
1 1/2	48.3 (1.90)	38 (1.50)	5.08 (0.20)	38 (1.50)
2	60.3 (2.38)	38 (1.50)	5.59 (0.22)	44 (1.75)
2 1/2	73.0 (2.88)	38 (1.50)	7.11 (0.28)	51 (2.00)
3	88.9 (3.50)	51 (2.00)	7.62 (0.30)	64 (2.50)
3 1/2	101.6 (4.00)	64 (2.50)	8.13 (0.32)	76 (3.00)
4	114.3 (4.50)	64 (2.50)	8.64 (0.34)	76 (3.00)
5	141.3 (5.56)	76 (3.00)	9.65 (0.38)	89 (3.50)
6	168.3 (6.62)	89 (3.50)	10.92 (0.43)	102 (4.00)
8	219.1 (8.62)	102 (4.00)	12.70 (0.50)	127 (5.00)
10	273.0 (10.75)	127 (5.00)	12.70 (0.50)	152 (6.00)
12	323.8 (12.75)	152 (6.00)	12.70 (0.50)	178 (7.00)
14	355.6 (14.00)	165 (6.50)	12.70 (0.50)	191 (7.50)
16	406.4 (16.00)	178 (7.00)	12.70 (0.50)	203 (8.00)
18	457.0 (18.00)	203 (8.00)	12.70 (0.50)	229 (9.00)
20	508.0 (20.00)	229 (9.00)	12.70 (0.50)	254 (10.00)
22	559.0 (22.00)	254 (10.00)	12.70 (0.50)	254 (10.00)
24	610.0 (24.00)	267 (10.50)	12.70 (0.50)	305 (12.00)
26	660.0 (26.00)	267 (10.50)
28	711.0 (28.00)	267 (10.50)
30	762.0 (30.00)	267 (10.50)
32	813.0 (32.00)	267 (10.50)
34	864.0 (34.00)	267 (10.50)
36	914.0 (36.00)	267 (10.50)
38	965.0 (38.00)	305 (12.00)
40	1 016.0 (40.00)	305 (12.00)
42	1 067.0 (42.00)	305 (12.00)
44	1 118.0 (44.00)	343 (13.50)
46	1 168.0 (46.00)	343 (13.50)
48	1 219.0 (48.00)	343 (13.50)

GENERAL NOTE: The shape of these caps shall be ellipsoidal and shall conform to the requirements given in the ASME Boiler and Pressure Vessel Code.

NOTES:

- (1) Length E applies for thickness not exceeding that given in column "Limiting Wall Thickness for Length, E"
 (2) Length E₁ applies for thickness greater than that given in column "Limiting Wall Thickness for Length, E" for NPS 24 and smaller. For NPS 26 and larger, length E₁ shall be by agreement between the manufacturer and purchaser.

Table 6.1-11 Dimensions of Reducers

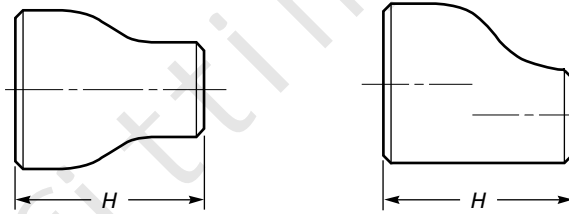

Nominal Pipe Size (NPS)	Outside Diameter at Bevel, mm (in.)			Nominal Pipe Size (NPS)	Outside Diameter at Bevel, mm (in.)		
	Large End	Small End	End-to-End, H, mm (in.)		Large End	Small End	End-to-End, H, mm (in.)
$\frac{3}{4} \times \frac{1}{2}$	26.7 (1.05)	21.3 (0.84)	38 (1.50)	5×4	141.3 (5.56)	114.3 (4.50)	127 (5.00)
$\frac{3}{4} \times \frac{3}{8}$	26.7 (1.05)	17.3 (0.68)	38 (1.50)	$5 \times 3\frac{1}{2}$	141.3 (5.56)	101.6 (4.00)	127 (5.00)
$1 \times \frac{3}{4}$	33.4 (1.32)	26.7 (1.05)	51 (2.00)	5×3	141.3 (5.56)	88.9 (3.50)	127 (5.00)
$1 \times \frac{1}{2}$	33.4 (1.32)	21.3 (0.84)	51 (2.00)	$5 \times 2\frac{1}{2}$	141.3 (5.56)	73.0 (2.88)	127 (5.00)
$1\frac{1}{4} \times 1$	42.2 (1.66)	33.4 (1.32)	51 (2.00)	5×2	141.3 (5.56)	60.3 (2.38)	127 (5.00)
$1\frac{1}{4} \times \frac{3}{4}$	42.2 (1.66)	26.7 (1.05)	51 (2.00)	6×5	168.3 (6.62)	141.3 (5.56)	140 (5.50)
$1\frac{1}{4} \times \frac{1}{2}$	42.2 (1.66)	21.3 (0.84)	51 (2.00)	6×4	168.3 (6.62)	114.3 (4.50)	140 (5.50)
$1\frac{1}{2} \times 1\frac{1}{4}$	48.3 (1.90)	42.2 (1.66)	64 (2.50)	$6 \times 3\frac{1}{2}$	168.3 (6.62)	101.6 (4.00)	140 (5.50)
$1\frac{1}{2} \times 1$	48.3 (1.90)	33.4 (1.32)	64 (2.50)	6×3	168.3 (6.62)	88.9 (3.50)	140 (5.50)
$1\frac{1}{2} \times \frac{3}{4}$	48.3 (1.90)	26.7 (1.05)	64 (2.50)	$6 \times 2\frac{1}{2}$	168.3 (6.62)	73.0 (2.88)	140 (5.50)
$1\frac{1}{2} \times \frac{1}{2}$	48.3 (1.90)	21.3 (0.84)	64 (2.50)	8×6	219.1 (8.62)	168.3 (6.62)	152 (6.00)
$2 \times 1\frac{1}{2}$	60.3 (2.38)	48.3 (1.90)	76 (3.00)	8×5	219.1 (8.62)	141.3 (5.56)	152 (6.00)
$2 \times 1\frac{1}{4}$	60.3 (2.38)	42.2 (1.66)	76 (3.00)	8×4	219.1 (8.62)	114.3 (4.50)	152 (6.00)
2×1	60.3 (2.38)	33.4 (1.32)	76 (3.00)	$8 \times 3\frac{1}{2}$	219.1 (8.62)	101.6 (4.00)	152 (6.00)
$2 \times \frac{3}{4}$	60.3 (2.38)	26.7 (1.05)	76 (3.00)	10×8	273.0 (10.75)	219.1 (8.62)	178 (7.00)
$2\frac{1}{2} \times 2$	73.0 (2.88)	60.3 (2.38)	89 (3.50)	10×6	273.0 (10.75)	168.3 (6.62)	178 (7.00)
$2\frac{1}{2} \times 1\frac{1}{2}$	73.0 (2.88)	48.3 (1.90)	89 (3.50)	10×5	273.0 (10.75)	141.3 (5.56)	178 (7.00)
$2\frac{1}{2} \times 1\frac{1}{4}$	73.0 (2.88)	42.2 (1.66)	89 (3.50)	10×4	273.0 (10.75)	114.3 (4.50)	178 (7.00)
$2\frac{1}{2} \times 1$	73.0 (2.88)	33.4 (1.32)	89 (3.50)	12×10	323.8 (12.75)	273.0 (10.75)	203 (8.00)
$3 \times 2\frac{1}{2}$	88.9 (3.50)	73.0 (2.88)	89 (3.50)	12×8	323.8 (12.75)	219.1 (8.62)	203 (8.00)
3×2	88.9 (3.50)	60.3 (2.38)	89 (3.50)	12×6	323.8 (12.75)	168.3 (6.62)	203 (8.00)
$3 \times 1\frac{1}{2}$	88.9 (3.50)	48.3 (1.90)	89 (3.50)	12×5	323.8 (12.75)	141.3 (5.56)	203 (8.00)
$3 \times 1\frac{1}{4}$	88.9 (3.50)	42.2 (1.66)	89 (3.50)	14×12	355.6 (14.00)	323.8 (12.75)	330 (13.00)
$3\frac{1}{2} \times 3$	101.6 (4.00)	88.9 (3.50)	102 (4.00)	14×10	355.6 (14.00)	273.0 (10.75)	330 (13.00)
$3\frac{1}{2} \times 2\frac{1}{2}$	101.6 (4.00)	73.0 (2.88)	102 (4.00)	14×8	355.6 (14.00)	219.1 (8.62)	330 (13.00)
$3\frac{1}{2} \times 2$	101.6 (4.00)	60.3 (2.38)	102 (4.00)	14×6	355.6 (14.00)	168.3 (6.62)	330 (13.00)
$3\frac{1}{2} \times 1\frac{1}{2}$	101.6 (4.00)	48.3 (1.90)	102 (4.00)	16×14	406.4 (16.00)	355.6 (14.00)	356 (14.00)
$3\frac{1}{2} \times 1\frac{1}{4}$	101.6 (4.00)	42.2 (1.66)	102 (4.00)	16×12	406.4 (16.00)	323.8 (12.75)	356 (14.00)
$4 \times 3\frac{1}{2}$	114.3 (4.50)	101.6 (4.00)	102 (4.00)	16×10	406.4 (16.00)	273.0 (10.75)	356 (14.00)
4×3	114.3 (4.50)	88.9 (3.50)	102 (4.00)	16×8	406.4 (16.00)	219.1 (8.62)	356 (14.00)
$4 \times 2\frac{1}{2}$	114.3 (4.50)	73.0 (2.88)	102 (4.00)	18×16	457 (18.00)	406.4 (16.00)	381 (15.00)
4×2	114.3 (4.50)	60.3 (2.38)	102 (4.00)	18×14	457 (18.00)	355.6 (14.00)	381 (15.00)
$4 \times 1\frac{1}{2}$	114.3 (4.50)	48.3 (1.90)	102 (4.00)				

Table 6.1-11 Dimensions of Reducers (Cont'd)

Nominal Pipe Size (NPS)	Outside Diameter at Bevel, mm (in.)		End-to-End, H, mm (in.)	Nominal Pipe Size (NPS)	Outside Diameter at Bevel, mm (in.)		End-to-End, H, mm (in.)
	Large End	Small End			Large End	Small End	
18 × 12	457 (18.00)	323.8 (12.75)	381 (15.00)				
18 × 10	457 (18.00)	273.0 (10.75)	381 (15.00)	36 × 34	914 (36.00)	864 (34.00)	610 (24.00)
				36 × 32	914 (36.00)	813 (32.00)	610 (24.00)
20 × 18	508 (20.00)	457.0 (18.00)	508 (20.00)	36 × 30	914 (36.00)	762 (30.00)	610 (24.00)
20 × 16	508 (20.00)	406.4 (16.00)	508 (20.00)	36 × 26	914 (36.00)	660 (26.00)	610 (24.00)
20 × 14	508 (20.00)	355.6 (14.00)	508 (20.00)	36 × 24	914 (36.00)	610 (24.00)	610 (24.00)
20 × 12	508 (20.00)	323.8 (12.75)	508 (20.00)				
				38 × 36	965 (38.00)	914 (36.00)	610 (24.00)
22 × 20	559 (22.00)	508.0 (20.00)	508 (20.00)	38 × 34	965 (38.00)	864 (34.00)	610 (24.00)
22 × 18	559 (22.00)	457.0 (18.00)	508 (20.00)	38 × 32	965 (38.00)	813 (32.00)	610 (24.00)
22 × 16	559 (22.00)	406.4 (16.00)	508 (20.00)	38 × 30	965 (38.00)	762 (30.00)	610 (24.00)
22 × 14	559 (22.00)	355.4 (14.00)	508 (20.00)	38 × 28	965 (38.00)	711 (28.00)	610 (24.00)
				38 × 26	965 (38.00)	660 (26.00)	610 (24.00)
24 × 22	610 (24.00)	559.0 (22.00)	508 (20.00)				
24 × 20	610 (24.00)	508.0 (20.00)	508 (20.00)	40 × 38	1 016 (40.00)	965 (38.00)	610 (24.00)
24 × 18	610 (24.00)	457.0 (18.00)	508 (20.00)	40 × 36	1 016 (40.00)	914 (36.00)	610 (24.00)
24 × 16	610 (24.00)	406.4 (16.00)	508 (20.00)	40 × 34	1 016 (40.00)	864 (34.00)	610 (24.00)
				40 × 32	1 016 (40.00)	813 (32.00)	610 (24.00)
26 × 24	660 (26.00)	610.0 (24.00)	610 (24.00)	40 × 30	1 016 (40.00)	762 (30.00)	610 (24.00)
26 × 22	660 (26.00)	559.0 (22.00)	610 (24.00)				
26 × 20	660 (26.00)	508.0 (20.00)	610 (24.00)	42 × 40	1 067 (42.00)	1 016 (40.00)	610 (24.00)
26 × 18	660 (26.00)	457.0 (18.00)	610 (24.00)	42 × 38	1 067 (42.00)	965 (38.00)	610 (24.00)
				42 × 36	1 067 (42.00)	914 (36.00)	610 (24.00)
28 × 26	711 (28.00)	660.0 (26.00)	610 (24.00)	42 × 34	1 067 (42.00)	864 (34.00)	610 (24.00)
28 × 24	711 (28.00)	610.0 (24.00)	610 (24.00)	42 × 32	1 067 (42.00)	813 (32.00)	610 (24.00)
28 × 20	711 (28.00)	508.0 (20.00)	610 (24.00)	42 × 30	1 067 (42.00)	762 (30.00)	610 (24.00)
28 × 18	711 (28.00)	457.0 (18.00)	610 (24.00)				
				44 × 42	1 118 (44.00)	1 067 (42.00)	610 (24.00)
30 × 28	762 (30.00)	711.0 (28.00)	610 (24.00)	44 × 40	1 118 (44.00)	1 016 (40.00)	610 (24.00)
30 × 26	762 (30.00)	660.0 (26.00)	610 (24.00)	44 × 38	1 118 (44.00)	965 (38.00)	610 (24.00)
30 × 24	762 (30.00)	610.0 (24.00)	610 (24.00)	44 × 36	1 118 (44.00)	914 (36.00)	610 (24.00)
30 × 20	762 (30.00)	508.0 (20.00)	610 (24.00)				
				46 × 44	1 168 (46.00)	1 118 (44.00)	711 (28.00)
32 × 30	813 (32.00)	762.0 (30.00)	610 (24.00)	46 × 42	1 168 (46.00)	1 067 (42.00)	711 (28.00)
32 × 28	813 (32.00)	711.0 (28.00)	610 (24.00)	46 × 40	1 168 (46.00)	1 016 (40.00)	711 (28.00)
32 × 26	813 (32.00)	660.0 (26.00)	610 (24.00)	46 × 38	1 168 (46.00)	965 (38.00)	711 (28.00)
32 × 24	813 (32.00)	610.0 (24.00)	610 (24.00)				
				48 × 46	1 219 (48.00)	1 168 (46.00)	711 (28.00)
34 × 32	864 (34.00)	813.0 (32.00)	610 (24.00)	48 × 44	1 219 (48.00)	1 118 (44.00)	711 (28.00)
34 × 30	864 (34.00)	762.0 (30.00)	610 (24.00)	48 × 42	1 219 (48.00)	1 067 (42.00)	711 (28.00)
34 × 26	864 (34.00)	660.0 (26.00)	610 (24.00)	48 × 40	1 219 (48.00)	1 016 (40.00)	711 (28.00)
34 × 24	864 (34.00)	610.0 (24.00)	610 (24.00)				

GENERAL NOTE: Although the figure illustrates a bell-shaped reducer, the use of a conical reducer is not prohibited.

(18)

Table 8-1 Welding Bevels and Root Face

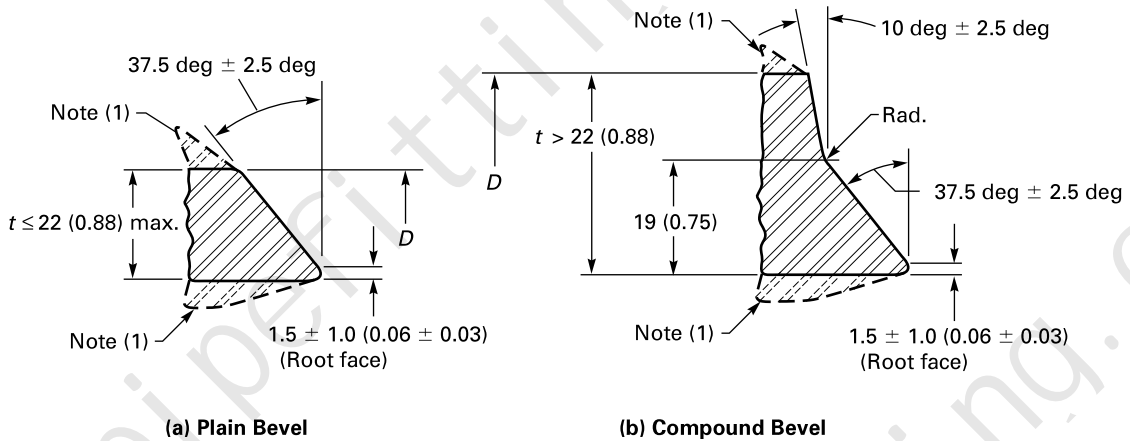

Nominal Wall Thickness, t , mm (in.)	End Preparation
Less than x [Note (2)]	Cut square or slightly chamfer, at manufacturer's option (not illustrated)
x to 22 (0.88), inclusive [Note (2)]	Plain bevel as in illustration (a) above
More than 22 (0.88)	Compound bevel as in illustration (b) above

GENERAL NOTE: In the illustrations, dimensions in parentheses are in inches; other dimensions are in millimeters.

NOTES:

(1) See section 8 and Figure 8-1 for transition contours.

(2) $x = 5$ mm (0.19 in.) for carbon steel or ferritic alloy steel and 3 mm (0.12 in.) for austenitic steel or nonferrous alloys.

(18)

Figure 8-1 Maximum Envelope for Welding End Transitions

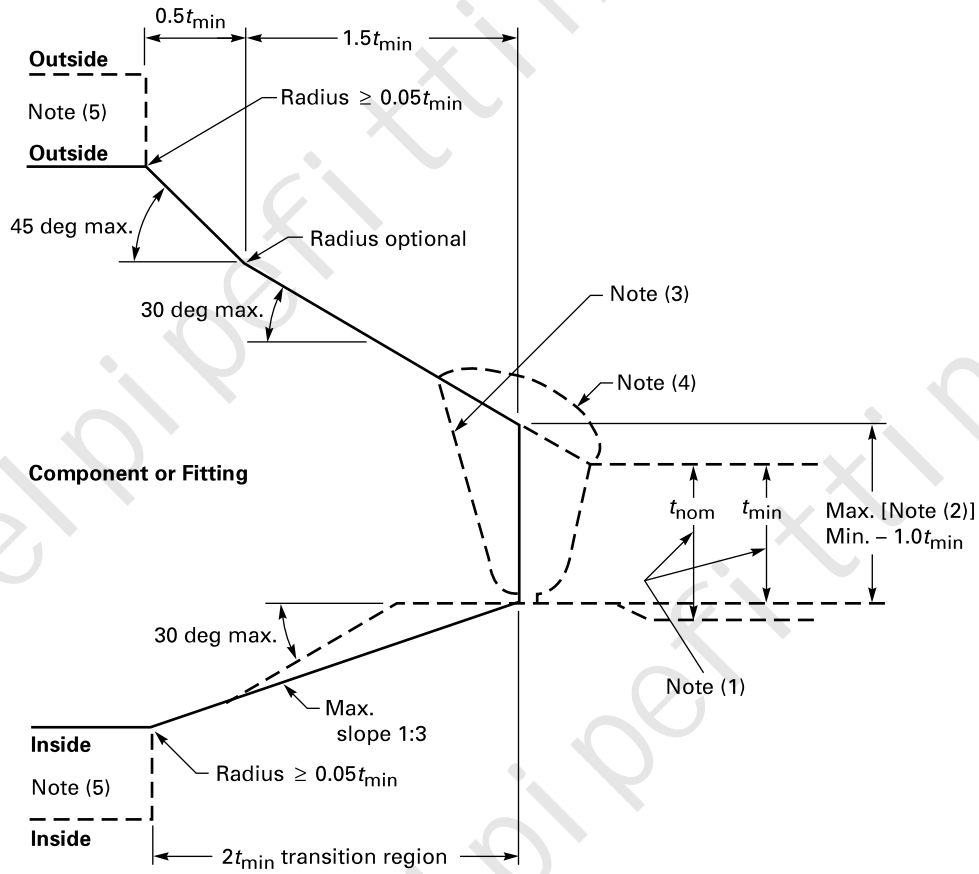

NOTES:

(1) The value of t_{min} is whichever of the following is applicable:

(a) the minimum ordered wall thickness of the pipe, to include pipe that is purchased to a nominal wall thickness with an undertolerance other than 12.5%

(b) 0.875 times the nominal wall thickness of pipe ordered to a pipe schedule wall thickness that has an undertolerance of 12.5%

(2) The maximum thickness at the end of the component is as follows:

(a) the greater of $[t_{min} + 4 \text{ mm (0.16 in.)}]$ or $1.15t_{min}$ when ordered on a minimum wall basis

(b) the greater of $[t_{min} + 4 \text{ mm (0.16 in.)}]$ or $1.10t_{nom}$ when ordered on a nominal wall basis

(3) Weld bevel shown is for illustration only.

(4) The weld reinforcement permitted by applicable code may lie outside the maximum envelope.

(5) Where transitions using maximum slope do not intersect the inside or outside surfaces within the transition region, as shown by the phantom outline, maximum slopes shall be used. Alternatively, radii lying within the envelope may be used.

Table 9.2.1-1 Testing Coverage

Type of Fitting Tested [Note (1)]	Qualifies the Following If the Same Design Thickness Is Used
Short radius elbow [Note (2)]	Short radius, long radius, reducing long radius, or 3D radius elbow
Long radius elbow [Note (2)]	Long radius, reducing long radius, or 3D radius elbow
3D radius elbow [Note (2)]	3D radius elbow
Straight tee	Straight or reducing tees of any reduction
Reducing tee	Reducing tees with the same or more reduction in outlet size
Straight cross	Straight or reducing crosses of any reduction
Reducing cross	Reducing crosses with the same or more reduction in outlet size
Cap	Caps of the same configuration
Eccentric reducer [Note (3)]	Eccentric or concentric reducers with the same or lesser included transition angle
Concentric reducer [Note (3)]	Concentric reducers with the same or lesser included transition angle [Note (4)]
Lap joint stub ends	Lap joint stub ends are exempt from proof

NOTES:

- (1) Paragraph 9.4 applies to as-tested and qualified fittings.
- (2) A test of any angle elbow covered in Tables 6.1-1 through 6.1-6 will qualify any other angle. A factory-made segment elbow that has a proof test on a geometrically similar 45-deg or 90-deg elbow need not be tested separately.
- (3) Straight conical (no tangent) and bell-shaped reducers are considered different design configurations and require separate testing.
- (4) "Transition angle" is defined as the angle of the conical section and is calculated as the $[\arctan(\text{difference of diameters}/\text{twice the length})]$ for concentric reducers or $[\arctan(\text{difference of diameters}/\text{length})]$ for eccentric reducers.

Table 9.3.1-1 Test Factor, *f*, Determination

Number of Tests Performed, or Number of Geometrically Similar Fittings Tested	Test Factor, <i>f</i>
One	1.10
Two	1.05
Three or more	1.0

Table 11-1 Tolerances

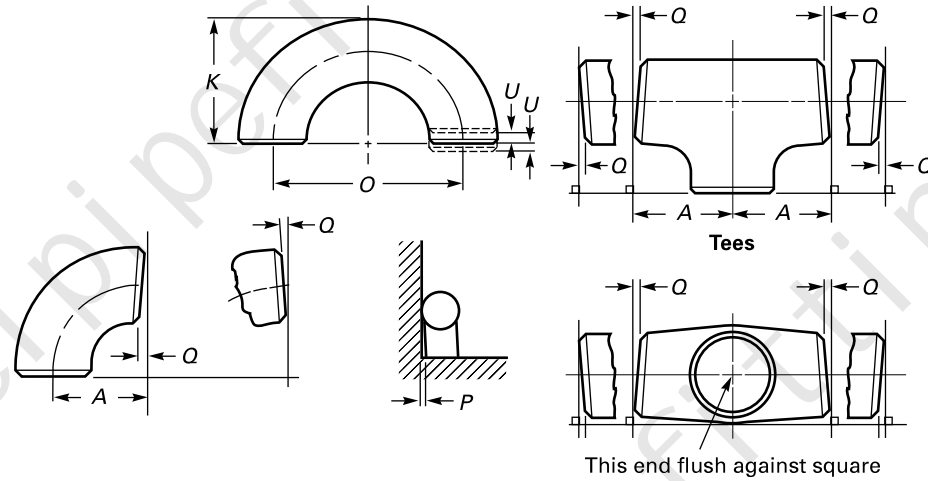

All Fittings [Notes (1) and (2)]		Center-to-End Dimensions, mm (in.)						180-deg Returns		
Nominal Pipe Size (NPS)	DN	Outside Diameter at Bevel, D, mm (in.) [Notes (3) and (4)]	Inside Diameter at End, mm (in.) [Notes (3) and (5)]	90-deg and 45-deg Long and Short Radius Elbows and Tees, A, B, C, M	3D Radius Elbows, A, B	Overall Length of Reducers and Lap Joint Stub Ends, F, H, mm (in.)	Overall Length of Caps, E, mm (in.)	Center-to-Center Dimension, O, mm (in.)	Back-to-Face Dimension, K, mm (in.)	Alignment of Ends, U, mm (in.)
1/2 to 2 1/2	15 to 65	+1.6, -0.8 (+0.06, -0.03)	0.8 (0.03)	2 (0.06)	3 (0.09)	2 (0.06)	3 (0.12)	6 (0.25)	6 (0.25)	1 (0.03)
3 to 3 1/2	80 to 90	1.6 (0.06)	1.6 (0.06)	2 (0.06)	3 (0.09)	2 (0.06)	3 (0.12)	6 (0.25)	6 (0.25)	1 (0.03)
4	100	1.6 (0.06)	1.6 (0.06)	2 (0.06)	3 (0.09)	2 (0.06)	3 (0.12)	6 (0.25)	6 (0.25)	1 (0.03)
5 to 8	125 to 200	+2.4, -1.6 (+0.09, -0.06)	1.6 (0.06)	2 (0.06)	3 (0.09)	2 (0.06)	6 (0.25)	6 (0.25)	6 (0.25)	1 (0.03)
10 to 18	250 to 450	+4.0, -3.2 (+0.16, -0.12)	3.2 (0.12)	2 (0.09)	3 (0.12)	2 (0.09)	6 (0.25)	10 (0.38)	6 (0.25)	2 (0.06)
20 to 24	500 to 600	+6.4, -4.8 (+0.25, -0.19)	4.8 (0.19)	2 (0.09)	3 (0.12)	2 (0.09)	6 (0.25)	10 (0.38)	6 (0.25)	2 (0.06)
26 to 30	650 to 750	+6.4, -4.8 (+0.25, -0.19)	4.8 (0.19)	3 (0.12)	6 (0.25)	5 (0.19)	10 (0.38)
32 to 48	800 to 1200	+6.4, -4.8 (+0.25, -0.19)	4.8 (0.19)	5 (0.19)	6 (0.38)	5 (0.19)	10 (0.38)

Lap Joint Stub Ends [Note (6)]					Angularity Tolerances, mm (in.)			
Nominal Pipe Size (NPS)	DN	Outside Diameter of Lap, G, mm (in.)	Fillet Radius of Lap, R, mm (in.)	Lap Thickness, mm (in.)	Nominal Pipe Size (NPS)	DN	Off Angle, Q	Off Plane, P
1/2 to 2 1/2	15 to 65	+0, -1 (+0, -0.03)	+0, -1 (+0, -0.03)	+1.6, -0 (+0.06, -0)	1/2 to 4	15 to 100	1 (0.03)	2 (0.06)
3 to 3 1/2	80 to 90	+0, -1 (+0, -0.03)	+0, -1 (+0, -0.03)	+1.6, -0 (+0.06, -0)	5 to 8	125 to 200	2 (0.06)	4 (0.12)
4	100	+0, -1 (+0, -0.03)	+0, -2 (+0, -0.06)	+1.6, -0 (+0.06, -0)	10 to 12	250 to 300	3 (0.09)	5 (0.19)
5 to 8	125 to 200	+0, -1 (+0, -0.03)	+0, -2 (+0, -0.06)	+1.6, -0 (+0.06, -0)	14 to 16	350 to 400	3 (0.09)	6 (0.25)

Table 11-1 Tolerances (Cont'd)

Nominal Pipe Size (NPS)	DN	Lap Joint Stub Ends [Note (6)]			Angularity Tolerances, mm (in.)			
		Outside Diameter of Lap, G, mm (in.)	Fillet Radius of Lap, R, mm (in.)	Lap Thickness, mm (in.)	Nominal Pipe Size (NPS)	DN	Off Angle, Q	Off Plane, P
10 to 18	250 to 450	+0, -2 (+0, -0.06)	+0, -2 (+0, -0.06)	+3.2, -0 (+0.12, -0)	18 to 24	450 to 600	4 (0.12)	10 (0.38)
20 to 24	500 to 600	+0, -2 (+0, -0.06)	+0, -2 (+0, -0.06)	+3.2, -0 (+0.12, -0)	26 to 30	650 to 750	5 (0.19)	10 (0.38)
26 to 30	650 to 750	32 to 42	800 to 1 050	5 (0.19)	13 (0.50)
32 to 48	800 to 1 200	44 to 48	1 100 to 1 200	5 (0.19)	19 (0.75)

GENERAL NOTE: Tolerances are equal plus and minus except as noted.

NOTES:

- (1) The inside diameter and the nominal wall thicknesses at ends are to be specified by the purchaser.
- (2) A minimum wall thickness of 87.5% applies unless the purchaser specifies a different wall thickness tolerance. See [Figure 8-1](#), Note (1)(a).
- (3) Out-of-round is the sum of absolute values of plus and minus tolerances.
- (4) This tolerance may not apply in localized areas of formed fittings where increased wall thickness is required to meet design requirements of [para. 2.2](#).
- (5) Unless otherwise specified by the purchaser, these tolerances apply to the nominal inside diameter, which equals the difference between the nominal outside diameter and twice the nominal wall thickness.
- (6) See [Table 6.1-9](#) for limiting dimensions of outside diameter of barrel.

MANDATORY APPENDIX I REFERENCES

(18)

The following is a list of standards and specifications referenced in this Standard. Unless otherwise specified, the latest edition of ASME publications shall apply.

ASME B16.5, Pipe Flanges and Flanged Fittings: NPS ½
Through NPS 24 Metric/Inch Standard

ASME B16.25, Buttwelding Ends

ASME B31, Code for Pressure Piping

ASME B31.3, Process Piping

ASME B36.10M, Welded and Seamless Wrought Steel Pipe

ASME B36.19M, Stainless Steel Pipe

ASME Boiler and Pressure Vessel Code

Publisher: The American Society of Mechanical Engineers
(ASME), Two Park Avenue, New York, NY 10016-5990
(www.asme.org)

ASTM A234/A234M-17, Specification for Piping Fittings
of Wrought Carbon Steel and Alloy Steel for Moderate
and High Temperature Service

ASTM A403/A403M-16, Specification for Wrought
Austenitic Stainless Steel Piping Fittings

ASTM A420/A420M-16, Specification for Piping Fittings
of Wrought Carbon Steel and Alloy Steel for Low-
Temperature Service

ASTM A815/A815M-14e1, Specification for Wrought
Ferritic, Ferritic/Austenitic and Martensitic Stainless
Steel Piping Fittings

ASTM A960/A960M-16a, Specification for Common
Requirements for Wrought Steel Piping Fittings

ASTM B361-16, Specification for Factory-Made Wrought
Aluminum and Aluminum-Alloy Welding Fittings

ASTM B363-14, Specification for Seamless and Welded
Unalloyed Titanium and Titanium Alloy Welding
Fittings

ASTM B366/B366M-17, Specification for Factory-Made
Wrought Nickel and Nickel Alloy Fittings

ASTM E29-13, Practice for Using Significant Digits in Test
Data to Determine Conformance With Specifications
Publisher: American Society for Testing and Materials
(ASTM International), 100 Barr Harbor Drive, P.O.
Box C700, West Conshohocken, PA 19428-2959
(www.astm.org)

ISO 6708:1995, Pipework components — Definition and
selection of DN (nominal size)

ISO 9000:2015, Quality management systems —
Fundamentals and vocabulary¹

ISO 9001:2015, Quality management systems —
Requirements¹

ISO 9004:2009, Managing for the sustained success of an
organization — A quality management approach¹

Publisher: International Organization for Standardization
(ISO), Central Secretariat, Chemin de Blandonnet 8, Case
Postale 401, 1214 Vernier, Geneva, Switzerland
(www.iso.org)

¹ May also be obtained from the American National Standards Institute
(ANSI), 25 West 43rd Street, New York, NY 10036.

NONMANDATORY APPENDIX A QUALITY SYSTEM PROGRAM

The products manufactured in accordance with this Standard shall be produced under a Quality System Program following the principles of an appropriate standard from the ISO 9000 series.¹ A determination of the need for registration and/or certification of the product manufacturer's quality system by an independent organization shall be the responsibility of the manufacturer. The detailed documentation demonstrating program

compliance shall be available to the purchaser at the manufacturer's facility. A written summary description of the program used by the product manufacturer shall be available to the purchaser upon request. The "product manufacturer" is defined as the entity whose name or trademark appears on the product in accordance with the marking or identification requirements of this Standard.

¹ The series is also available from the American National Standards Institute (ANSI) and the American Society for Quality (ASQ) as American National Standards that are identified by the prefix "Q," replacing the prefix "ISO." Each standard of the series is listed under References in [Mandatory Appendix I](#).

ASME B16.9-2018

hysteel pi pe fi tti ng. com
sales@hysteel pi pe fi tti ng. com

ISBN 978-0-7918-7209-3



9 780791 872093



J 1 0 9 1 8